

PROJECT:

City of Parkville
Friends of Parkville Parks Shelter



OWNER:

City of Parkville, Missouri

DATE: July 6, 2017

City of Parkville
Construction Documents

Table of Contents

1. Notice to Bidders – Advertisement for Bids
2. Instructions to Bidders
3. Bid Form – Lump Sum Bids
4. Notice of Award
5. Agreement Between City of Parkville and Contractor
6. Exhibit A – General Conditions of the Contract for Construction
7. Exhibit A-1 – Special Conditions
8. A. Exhibit B-1 – Performance Bond
B. Exhibit B-2 – Payment Bond
C. Exhibit B-3 - Maintenance Bond
9. Exhibit C –Drawings
10. Exhibit D –Specifications
11. Exhibit E – Contractor's Affidavit Acknowledging Federal Lobbying Activities and Conflict of Interest Prohibition
12. Exhibit F – Sales Tax Exemption Documentation
13. Exhibit G – Contractor's Affidavit of Compliance with Non-Discrimination and Equal Employment Opportunity Laws
14. Exhibit H – Affidavit of Compliance with Safety Training Requirements
15. Exhibit I – Affidavit of Compliance with R.S. Mo. § 285.530.5
16. A. Exhibit J-1 – (Applicable Missouri Prevailing Wage Statutes)
B. Exhibit J-2 – Prevailing Wage Reporting Form)
C. Exhibit J-3 – Certification of Compliance with Prevailing Wage Requirements
17. Exhibit K – Insurance Requirements
18. Exhibit L – Bill of Sale

19. Exhibit M – Bailment Agreement
20. Exhibit N – Conditional Partial Release of Lien and Waiver of Claims
21. Exhibit O – Conditional Final Waiver of Lien and Release of Claims
22. Certificate of Substantial Completion
23. Certificate of Final Completion
24. Construction Change Directive
25. Change Order

NOTICE TO BIDDERS – ADVERTISEMENT FOR BIDS
CITY OF PARKVILLE, MISSOURI

The City of Parkville, Missouri is seeking sealed bids for the following:

FRIEND'S OF PARKVILLE PARK SHELTER

Sealed bids will be received by the City of Parkville Missouri, 8880 Clark Avenue Parkville, MO 64152 Attn: Alysen Abel, Public Works Director, until 10:00 am, Tuesday, August 1, 2017. Deliveries shall be made to the reception desk of City Hall. Bids will be publicly opened and read aloud at approximately 10:05 am in the Public Works Conference Room of City Hall.

Bids shall be on a lump sum basis for the Base Bid. The work generally includes:

Construction of a Park Shelter, to match the existing shelters in English Landing Park, as outlined in the attached specifications.

and other items as specified in the bidding documents and amendments thereto. See bidding documents for a complete project and bidding information.

A complete set of bidding documents may be viewed and purchased at the following locations, beginning July 6, 2017.

A complete set of bidding documents may be viewed and at the following location, beginning Thursday, July 6, 2017. Copies of the bidding documents may be obtained from this location in hard copy or electronic format. Refer to the plan room's website.

Drexel Technologies Plan Room
10840 W. 86th Street
Lenexa, KS 66214-1632
(913) 371-4430
www.drexeltech.com

Bidding documents are also on file for examination at Parkville City Hall.

No pre-bid meeting is scheduled associated with this project. Questions concerning this bid can be directed to Alysen Abel, Public Works Director at (816) 741-7676.

INSTRUCTIONS TO BIDDERS

IMPORTANT: Please read all bid package documents carefully. Forms contained herein cover terms on legal requirements, including Prevailing Wages; Employment Eligibility verification; OSHA training certification; and surety bonds. If selected by the City, a contractor will not be excused from any contractual requirement due to failure to fully read all forms and appreciate their scope.

- IB-1. BIDS: All bids shall be made on the forms provided in this bound volume of Contract Documents and shall be in compliance with these Instructions to Bidders. All appropriate blanks shall be filled in and shall be signed by the appropriate individual on behalf of him/herself or the entity submitting the bid. If a Bid Bond is used, it must be properly executed by the Contractor and its surety shall be submitted simultaneously. Each bid must be enclosed in a sealed envelope plainly marked "BID FOR **FRIEND'S OF PARKVILLE PARK SHELTER**." As per Notice to Bidders, bids shall be addressed to:

CITY OF PARKVILLE, MISSOURI
Attention: Alysén M. Abel, Public Works Director
City Hall
8880 Clark Avenue
Parkville, MO 64152

Bids must be complete; legible; contain no qualifications or exceptions; and received at the place and by the time designated in the Notice to Bidders. The burden is on the Bidder to comply with all such requirements, and the failure of any Bidder to abide by the City's requirements for submission of bids shall be grounds for rejection of the Bid in the sole discretion of the City.

IB-2. DEFINITIONS:

- a. An Alternate is an amount stated in the Bid to be added to or deducted from the amount of the Base Bid if the corresponding change in the work, as described in the Bidding Documents, is accepted.
- b. An Addendum is a document issued by the City after initial issuance of the Notice to Bidders and Bidding Documents, which contains additional or different information pertinent to the Project to be awarded.
- c. The Base Bid is the sum stated in the Bid for which the bidder offers to perform the Work described in the Bidding Documents as the base, to which Work may be added or from which Work may be deleted for sums stated in Alternate Bids.
- d. A Bid is a complete and properly signed proposal to do the Work or designated portion of thereof for the price stipulated therein, submitted in accordance with the Bidding Documents.
- e. A Bidder is a person or entity who submits a Bid.
- f. Bidding Documents include the Notice to Bidders, Instructions to Bidders, the Bid Form, other sample bidding and contract forms and the proposed Contract Documents, including any Addenda issued prior to receipt of Bids. The Contract Documents proposed for the Work consist of the items enumerated in the General Conditions of the Contract for Construction. All definitions set forth in the General Conditions or in other Contract Documents are applicable to the Bidding Documents.

- g. A Bid Form will be included in the Bidding Documents, and Bidders are required to fill it out as instructed in the Bidding Documents.
- h. Contractor shall be the Bidder that the City has determined and declared to be the successful Bidder and which has, following such determination and declaration, thereafter executed a Contract for construction with the City to perform the Work described therein.
- i. Notice of Award shall mean the written notice by the City to the apparent successful Bidder stating that upon compliance with the conditions precedent enumerated therein, within the time specified, the City will sign and deliver the Contract.
- j. Notice to Bidders shall mean the document issued by the City inviting bids, advising bidders of where Bidding Documents are available; the cost, if any, for obtaining Bidding Documents; the time and place of Bid submission and Bid opening;
- k. The Site is the physical location where the Project work will be constructed.
- l. Successful Bidder is the person or entity who is determined and declared by the City to have submitted the lowest and best responsible Bid in the conformity with the terms of the Bidding Documents.
- m. A Unit Price is an amount stated in the Bid as a price per unit of measurement for materials or services as described in the Bidding Documents or in the proposed Contract Documents

IB-3 BIDDER'S REPRESENTATIONS: Each Bidder by making a Bid represents that:

- a. Bidder has read and understands the Bidding Documents and his bid is made in accordance therewith.
- b. Bidder has visited the proposed Site, has familiarized itself with the weather, traffic and site conditions under which the Work is to be performed, has reviewed all published reports, inspections and other documents relating to the Project made available by the City to Bidders, and has correlated its observations with the requirements of the proposed Contract Documents.
- c. Bidder's Bid is based upon the materials, systems and equipment required by the Bidding Documents, except such substitutions approved by the Public Works Director through issuance of Addenda.
- d. Bidder has familiarized itself with the state, federal and local ordinances and regulations, which may affect cost, progress or performance of the Work.
- e. Bidder will execute the Contract and be bound to all the Contract Documents upon its selection by the City.

IB-4 BIDDING DOCUMENTS: Bidders may obtain complete sets of the Bidding Documents from the City in the number and for the sum stated in the Notice to Bidders.

Bidders shall use complete sets of Bidding Documents in preparing Bids; neither the City nor the Public Works Director assumes any responsibility for errors or misinterpretations resulting from the use of incomplete sets of Bidding Documents.

The City in making copies of the Bidding Documents available on the above terms does so only for the purpose of obtaining Bids on the Work and does not confer a license or grant for any other use.

IB-5 BID FORM

- a. Prospective Bidders are furnished one copy of the Bidding Documents and one set of the Contract Drawings and one copy of the Bid form. The unbound set of Bid Form shall be filled out as set forth herein and submitted with the Bid Security and other documents as noted in these instructions. The bound Bidding Documents shall not, for any reason, be unbound. If the Bid Form or any of the Bid Form attachments are modified by Addendum, revised forms will be issued, in which case Bids shall be submitted on the latest revisions of the forms issued. No alteration whatsoever shall be made in the printed Bid Form, and no alternative items not requested by the printed form shall be written in, nor shall any conditions to the Bid as submitted be written into the Bid Form. If alterations or changes are made to the printed Bid Form, or if unrequested alternatives are written in, or if conditions are written into the Bid as submitted, the Bid may be considered as nonresponsive and may not be considered for award of a contract.
- b. Bids shall be submitted on the Bid Form provided with the Bidding Documents. All blank spaces shall be properly and legibly filled in with ink or typed. A base bid manufacturer must be indicated for each item of material and equipment listed in the Bid Form. Where material and equipment manufacturers are named in the Specifications, the base bid must indicate one of the named manufacturers. If the Bidder wishes to propose a substitute equipment manufacturer for the equipment items listed, Bidder shall make written application to Engineer, subject to the deadline and conditions set forth in these Instructions to Bidders.
- c. Bids by individuals shall be signed by the person making such Bid or the Bid must have attached thereto a power-of-attorney evidencing authority to sign the Bid in the name of the person for whom it is signed. The business address and telephone number of the individual shall also be provided.
- d. Bids by corporations shall be executed by the legal corporate name thereof, and the signature of the president or other authorized officer (accompanied by evidence of authority to sign) manually written below the corporate name and the attesting signature of the secretary or the assistant secretary of the corporation. The corporate address and state of incorporation shall be provided.
- e. Bids by partnerships must be signed in the true name of the partnership, and the signature of the partner or partners authorized to sign (accompanied by evidence of authority to sign) shall be manually written below the partnership name. The official address of the partnership must also be provided.
- f. The names of all persons signing must also be legibly printed in ink below the signature.
- g. The Bid shall contain an acknowledgment of receipt of Addenda, in accordance with these Instructions to Bidders.
- h. The address and telephone number for communications regarding the Bid must be shown.
- i. The Bidder's Contractors' Licenses as required by state statutes and local ordinances, codes and regulations, shall be typed or printed in ink, when applicable, on the Bid Form, where indicated.
- j. Bidders shall submit the required information on any additional forms provided as part of the Bidding requirements. All blank spaces shall be properly filled in ink or typed, in accordance with the requirements of these Instructions to Bidders and each form.
- k. Oral, telephone, fax, or telegraph Bids are invalid and will not receive consideration.
- l. Bidders shall assume full responsibility for timely delivery at the location designated for receipt of Bids.

- m. The bid time will be monitored by the clock in the City Clerk's Office. Inaccuracy of City's clock to other time measurement entities will not excuse late arrival of bids.
- n. The following items are to be included with each Bid. This list is included to aid the Bidder in submitting a complete and responsive Bid. It cannot be relied on to include all items necessary to insure a responsive Bid. The Bidder is solely responsible for including all items required by the Bidding Documents, including any items required by Addenda, which may not be included in the below list:
 - 1. The completed Bid Form.
 - 2. Acknowledgment of Receipt of Addenda (the number and date of which shall be filled in on the Bid Form).
 - 3. Satisfactory evidence of authority of the person signing on behalf of the individual, firms, partnership or corporation shall be attached to the Bid Form.
 - 4. Bid Security, or Bid Bond with Power of Attorney attached to the Bid Bond.
 - 5. Contractor's license or certificate numbers shall be filled in on the Bid Form.
 - 6. List of Subcontractors, as set forth above
 - 7. Evidence that the Bidder is properly qualified to do business in the state of Missouri and in the county of Platte.
 - 8. The name, address, and telephone to which communications regarding the Bid are to be directed shall be written on the outside of the Bid envelope and filled in on the Bid Form.
 - 9. Required certifications.
 - 10. Required evidence of domicile as explained below.

IB-6 DEFECTS IN BIDDING/ CONTRACT DOCUMENTS: Bidders shall promptly notify the City of any errors, omissions, discrepancies or inconsistencies (hereinafter "defects") which they may discover upon examination of the Bidding Documents of the site and local conditions .

Bidders requiring clarification or interpretation of the Bidding Documents shall make a written request, which shall reach the Public Works Director at least seven days prior to the date for receipt of Bids.

Any interpretation, correction or change of the Bidding Documents will be made by Addendum. Interpretations, corrections or changes of the Bidding Documents made in any other manner will not be binding, and Bidders shall not rely upon such interpretations, corrections and changes.

As noted in the General Conditions, Bidders will not be permitted to take advantage of any such defect.

IB-7 SUBSTITUTIONS: The materials, products and equipment described in the Bidding Documents establish a standard of required function, dimension, appearance and quality to be met by any proposed substitution.

No substitution will be considered prior to execution of the Contract, unless written request for approval has been received by the Public Works Director at least seven (7) days prior to the date for receipt of Bids. Each such request shall include the name of the material or equipment for which it is to be substituted and a complete description of the proposed substitute including drawings, cuts, performance and test data and other information necessary for an evaluation. A statement setting forth any changes in other materials, equipment or other work that incorporation of the substitute would require shall be included. The proposed substitute shall meet all the same criteria as is set out in the Contract Documents for substitutions after award of the Contract, and the burden of proof of the merit of the proposed substitute is upon the Bidder. The Public Works Director's decision of approval or disapproval of a proposed substitution shall be final.

If the Public Works Director approves any proposed substitution prior to receipt of Bids, such approval will be set forth in a written addendum. Bidders shall not rely upon approvals made in any other manner.

- IB-8 ADDENDA: Written addenda will be mailed or delivered to all who have identified themselves in writing to the Public Works Director as requesting a complete set of Bidding Documents. Copies of the written addenda will be made available for inspection wherever Bidding Documents are on file for that purpose.

No written addenda will be issued later than four days prior to the date for receipt of Bids.

Each Bidder shall ascertain prior to submitting his Bid that he has received all written addenda issued, and **it shall acknowledge its receipt in its Bid**. Failure to acknowledge all Addenda could result in rejection of bids.

- IB-9 INSURANCE: Bidders are referred to **Exhibit C** to the Contract which sets for the insurance requirements.

- IB-10 BID SECURITY: Each Bid shall be accompanied by a bid bond issued by a corporate surety qualified to do business in the State of Missouri, accompanied by a certified copy of a Power of Attorney attesting to his or her authority to sign Bonds and conduct business in the State of Missouri, or a certified cashier's check on an acceptable bank, made payable, without condition, to the City in an amount of not less than five percent (5%) of the total Bid. In addition to other legal remedies, the amount of said Bid is accepted and the successful Bidder fails to enter into a Contract in the form prescribed, and submit insurance documents and Performance and Statutory Payment Bonds (if required for the project) within the time specified in the notice of award by the City; provided, however, that the City shall not necessarily be limited in protecting its legal rights to enforcement of its rights under the bid security.

The Bid Security of a Successful Bidder will be retained until such Bidder has executed the Contract and furnished the required Contract Security, whereupon the Bid Security will be returned. If the Successful Bidder fails to execute and deliver the Contract and furnish the required Contract Security within fifteen (15) days after the Notice of Award, the City may annul the Notice of Award, and the Bid Security of that Bidder shall be forfeited to the City. Should the City be required to engage the services of an attorney in connection with the enforcement of Bids, Bidder agrees to pay City's reasonable costs, including attorney fees, and all court, arbitration, or hearing costs incurred with or without suit. The Bid Security of any Bidder whom the City believes to have a reasonable chance of receiving the award may be retained by the City until the earlier of the sixtieth (60th) day after Bid opening or seven (7) days after the Effective Date of the Contract, whereupon Bid Security furnished by such Bidders will be returned. Bid security of other Bidders will be returned approximately seven (7) consecutive calendar days after the Bid opening.

- IB-11 TAXES: It is the intent of the City to supply the Contractor with a Sales and Compensating Tax Exemption certificate for use in purchasing materials and supplies on the Project. The Contractor shall, in preparing its Bid, omit from its computed costs all sales and compensation taxes.

- IB-12 LIQUIDATED DAMAGES: In case of failure on the part of the Contractor to effect completion within the time specified, the City shall have the right to assess against the Contractor as liquidated damages, fixed and agreed to in advance, in the amount stated in the Contract for each of the 24-hour calendar day, including Sundays and holidays. The daily rate for Liquidated Damages for this project is \$100.00.

- IB-13 MODIFICATIONS OR WITHDRAWAL OF BIDS: Bids may be modified or withdrawn by written request received in the office of the City Clerk, prior to the time and date for Bid opening. No

Bidder may withdraw its Bid for a period of thirty (30) days after the date set for the opening thereof.

IB-14 OPENING OF BIDS: All Bids received within the announced closing time for the receipt of Bids stipulated in the Advertisement for Bids will be opened publicly. Bids will be read aloud and a tabulation of the applicable Total Bid Price and major alternates (if any) will be made available to Bidders within a reasonable time after the opening of Bids. Any Bid received after the announced closing time may be returned unopened. Any uncertainties as to whether a Bid was submitted in time will be resolved at the City's sole discretion.

IB- 15 AWARD OF CONTRACT

- a. To the extent permitted by applicable state and federal laws and regulations, the City reserves the right to reject any and all Bids, to waive any and all informalities, and to disregard all nonconforming, nonresponsive, or conditional Bids, to re-advertise for Bids, and to negotiate with the lowest responsive, responsible bidder. Also, the City reserves the right to reject the Bid of any Bidder if the City believes that it would not be in the best interest of the Project to make an award to that Bidder, whether because the Bid is not responsive or the Bidder is unqualified or of doubtful financial ability, or has a record of poor performance with the City, other municipalities, or other clients or fails to meet any other pertinent standard or criteria established by the intent of the Bidding Documents.
- b. A Bid will be considered responsive if it conforms in all respects with the requirements of the Bidding Documents. In order to be considered responsive, a Bid shall: (a) be completed, signed and be responsive in all respects to the Bidding Requirements; (b) be made on the Bid Forms provided with the Bidding Documents and submitted in accordance with the applicable Bidding Requirements; and (c) include all additional documents provided with the Bidding Documents and submitted in accordance with the applicable Bidding Requirements.
- c. In order to be considered responsible, a Bidder must establish to the complete satisfaction of the City, as a minimum, that he has: (a) adequate financial resources to meet his contractual obligations and will maintain same for the Contract Time; (b) adequate equipment to perform the Work properly and within the Contract Time; (c) evidence of the necessary experience and technical qualifications in the type of Work provided for in the Contract; (d) conform to all conditions contained in these Bidding documents; (e) and his proposed Subcontractors, Suppliers or other persons or organizations hold valid State, county and local licenses or certificates covering all operations or specialty trades and areas of political jurisdiction involved in the Work; (f) has conformed to the pre-award Qualification Submittals requirement outlined in these Instructions to Bidders, if applicable, and (g) does not have a documented record of past projects resulting in arbitration or litigation in which he was found to be at fault. Operating costs, maintenance considerations, performance data and guarantees of materials and equipment may also be considered by the City.
- d. Upon request by the City, after the Bid Opening, a Bidder will furnish evidence of the above, including the requirements set forth herein for relevant project experience.
- e. Discrepancies on the Bid Form between words (if required) and figures shall be resolved so that the written words shall be binding on that Bidder. Discrepancies between the indicated sum of any column of figures and the correct sum will be resolved so that the correct sum shall be binding on that Bidder. Discrepancies in the multiplication of unit prices times the indicated units of Work will be resolved so that the proposed unit prices shall be binding on the Bidder. Discrepancies between a stipulated price and that indicated shall be resolved so that the stipulated allowance, or "no more than" or "no less than" price, shall be binding on that Bidder.

- f. In evaluating Bids, the City will consider the qualifications of the Bidders, whether or not Bids comply with the prescribed requirements, and such alternates, unit prices and other data, as may be requested in the Bid Form or prior to the Notice of Award.
- g. The City may conduct such investigations as the City deems necessary to assist in the evaluation of any Bid and to establish the responsibility, qualifications, and financial ability of the Bidders, proposed Subcontractors, Suppliers and other persons and organizations to do the Work in accordance with the Contract Documents, to the City's satisfaction, and within the prescribed Contract Time. The City reserves the right to reject the Bid of any Bidder who does not pass any such evaluation to the City's satisfaction.
- h. If the Contract for the Work is to be awarded, it will be awarded to the lowest, responsible, responsive Bidder pursuant to the requirements of the Bidding Documents, as determined by the City's evaluation of the corresponding Bid Form. In order to be considered the lowest Bidder, that Bidder will have provided the lowest Total Bid Price, in accordance with all applicable Bidding Requirements, and as determined by the City's and the Public Works Director's evaluation of the corresponding Bid Form.
- i. If a Contract is to be awarded, the Bidder will be given a Notice of Award within the time set forth in Article 15.0 of these Instructions to Bidders.
- j. Payment and Performance Bonds are required for this Project.

IB- 16 AWARD OF CONTRACT

The City reserves the right to apply a local preference in awarding the contract. The City of Parkville Purchasing Policy (as adopted by Resolution No. 10-02-14) states the City's intention to purchase from local suppliers, within reason, as it selects the best and most reasonably priced source for each transaction. The local residence of a supplier may be a factor considered in selecting among bidders on a purchase. It is the determination of the Governing Body that, in certain instances, choosing a local supplier serves the valid public purpose of supporting local businesses that, among other attributes, pay taxes to the City.

IB-17 EXECUTION OF THE CONTRACT

- a. The Notice of Award will establish the Contract Price and establish the adjustment unit price if accepted by the City at the City's sole discretion. A Notice of Award to a Successful Bidder will be accompanied by four (4) copies of unsigned counterparts of the corresponding Contract with all other written Contract Documents attached. The successful Bidder (Contractor) shall execute the Contract, insert copies of required bonds and power of attorney, and submit all copies to the City Clerk along with insurance certificates and Additional Insured and Notice of Cancellation Endorsements, within fifteen (15) days from the receipt of Notice of Award. The date of contract on the Contract and Bond forms shall be left blank for filling in by the City.
- b. The City shall execute all copies, insert the effective date on the Contract, Bonds and power of attorney (if required), and return all copies to the Public Works Director for review and distribution. Distribution of signed copies shall be one (1) copy each to the City Clerk, Contractor, Surety, and to the Public Works Director.
- c. Within fifteen (15) consecutive calendar days of receipt of Contract and other required documents by the City from the Contractor, the City Clerk will deliver two (2) fully signed counterparts (one for Contractor and one for surety) to Contractor. Notice to Proceed and requirements for commencement of the Contract Time set forth in the General Conditions.

- d. Failure by the Successful Bidder awarded the Contract to execute the Contract or to furnish the required Bonds shall be just cause for the annulment of the award and the forfeiture of that Bidder's Bid Security.

IB-18 CONFLICT OF INTEREST: 31 U.S.C.S. Section 1352 requires that all subgrantees, contractors, subcontractors and consultants who receive federal funds via the City to certify that they will not use federal funds to pay any person for influencing or attempting to influence a federal agency or Congress in connection with the award of any federal contract, grant, loan or cooperative agreements.

IB-19 IDENTIFICATION OF PROPOSED SUBCONTRACTORS AND SUPPLIERS

With the Bid Form, each Bidder shall identify the names, addresses and associated information of those Subcontractors, Suppliers or other persons or organizations, including those who are to furnish the principal items of material and equipment, whom Bidder intends to award a Subcontract or Purchase Order in an amount in excess of two (2) percent of the Total Bid Price. In addition, if requested by the City or Public Works Director, each Bidder shall be prepared to submit, within ten (10) consecutive calendar days, a "Qualifications Statement List" for all Subcontractors, Suppliers, or other persons or organizations so identified. This List shall include the name and address of the Subcontractor, Supplier, or other person or organization and a description of the services, materials or equipment to be supplied. Each nominated Subcontractor shall include the Subcontractor's license or certification, as applicable, as evidence that the firm is properly licensed or holds the required certificate for the specialty work involved. Such list shall be accompanied by a copy of the anticipated Subcontract or Purchase Order and by an experience statement with pertinent information as to similar projects and other information pertaining to financial resources, adequacy and availability of plant and equipment, organization, and other facts as evidence of qualifications to perform the Work designated for each such Subcontractor, Supplier or other person or organization. The list of principal items of equipment shall include the name of the locations at which similar size and type of equipment, as that specified, is in service.

If the City or the Public Works Director after due investigation of a Bid has reasonable objection to any proposed Subcontractor, Supplier or other person or organization, the City may, before giving Notice of Award, request such Bidder to remove or replace said proposed Subcontractor, Supplier or other person or organization and to self-perform the associated parts of the Work, if the Bidder holds a valid license or certificate for that work and he is so qualified, or to submit an acceptable substitute, without an increase in such Bidder's Bid, and without an increase in any of the proposed alternate prices. If such Bidder declines, the Contract shall not be awarded to such Bidder, but his declining to make any such substitution will not constitute grounds for sacrificing his Bid Security.

Any Subcontractor, Supplier, other person or Organization so listed and to whom the City or the Public Works Director does not make written objection prior to the Notice of Award will be deemed acceptable to the City and Public Works Director, subject to revocation of such acceptance after the Effective Date of the Contract as provided in the General Conditions.

IB-20 QUALIFICATIONS OF BIDDERS

Bidders may be required to submit satisfactory evidence that they have a practical knowledge of the particular work bid upon and that they have the necessary financial resources to complete the proposed Work.

Successful Bidder shall have completed at least three projects in the past five (5) years that involve sanitary sewer construction.

In determining the lowest responsible Bid, the following elements will be considered: Whether the Bidder involved (a) maintains a permanent place of business; (b) has adequate plant and equipment to do the Work properly and expeditiously; (c) has suitable financial status to meet obligations incidental to the Work; (d) has appropriate technical experience; (e) has materials available; and (f) has competent subcontractors, material and equipment manufacturers (g) acceptable reference review; (h) has been in business and has satisfactorily performed work similar to that required by this project for at least 5 years.

Each Bidder may be required to show that former Work performed by him has been handled in such manner that there are no just or proper claims pending against such Work. No Bidder will be acceptable if he is engaged on any other work, which impairs his ability to finance this Work or provide equipment for the proper execution of same. Each Bidder shall demonstrate his ability by meeting all requirements herein stipulated if asked for them.

Each Bid shall contain evidence that the Bidder is properly qualified to do business in the State, county, and city where the Project is located by disclosing that the Bidder and his nominated Subcontractors hold valid licenses and certificates, if applicable, issued by those Public Government Bodies with jurisdiction over the Work.

BID FORM
LUMP-SUM BIDS
FOR
FRIENDS OF PARKVILLE PARK SHELTER
CITY OF PARKVILLE, MISSOURI

Submitted by: _____

To: City of Parkville, Missouri:

THE UNDERSIGNED BIDDER, having examined the Instructions to Bidders, Contract Forms, Drawings, Specifications, General Conditions, Special Conditions, and other related Contract Documents referred to herein, and any and all Addenda thereto; the location, arrangement, and construction of existing railways, highways, streets, roads, structures, utilities, and facilities which affect or may be affected by the Work; the topography and condition of the site of the Work; and being acquainted with and fully understanding (a) the extent and character of the Work covered by this Bid Form; (b) the location, arrangement, and specified requirements of and for the proposed structures and miscellaneous items of Work appurtenant thereto; (c) the nature and extent of the excavations to be made, and the type, character and general condition of the materials to be excavated; (d) the necessary handling and re-handling of excavated materials; (e) all existing and local conditions relative to construction difficulties and hazards, labor, transportation, hauling, trucking and rail delivery facilities; and (f) all local conditions, laws, regulations, and all other factors and conditions affecting or which may be affected by the performance of the Work required by the Contract Documents.

HEREBY PROPOSES and agrees, if this Bid is accepted, to enter into agreement in the form attached hereto, and to perform all Work and to furnish all required materials, supplies, equipment, tools and plant; to perform all necessary labor; and to construct, install, erect and complete all Work stipulated in, required by, in accordance with the Contract Documents and other terms and conditions referred to therein (as altered, amended, or modified by any and all Addenda thereto) at the prices set forth in the following Schedule of Prices.

Bidder hereby agrees to commence Work under this Contract on the thirtieth day after the Effective Date of the Agreement or, if a Notice to Proceed is given, on the day indicated in the Notice to Proceed. A Notice to Proceed may be given at any time within thirty days after the Effective Date of the Agreement. The Bidder agrees to fully complete all Work within the time frame as provided for in the Agreement.

Bidder further agrees, if the Bid is accepted, to pay as an agreed amount of liquidated damages at the rate of \$100.00 per day, as provided in the Agreement, General Conditions, and Special Conditions.

Bidder accepts the provisions of the Instructions to Bidders regarding disposition of Bid Security.

Bidder acknowledges receipt of the following Addenda, which have been considered in the preparation of this Bid:

No. _____ Dated: _____
No. _____ Dated: _____

Failure to furnish all information requested below may be cause for rejection of the Bid.

Bidder agrees, if the Bid is accepted, to perform all the Work described in the Contract Documents, including all Addenda, for the price set forth below.

Park Shelter Specifications shall include:

Roof Dimensions	20' X 40'
Frame Dimensions	16' X 18'
Minimum Clearance	7'6"
Gable Roof	4:12 Pitch
Square Feet Under Roof	800

- Columns shall be 6" X 6" steel tube, minimum 0.120" wall thickness
- All beams shall be structural steel tube sized according to engineering
- All bolts shall be A-325 or A-307 and hidden at all connections
- Roofing shall be 24 gauge HR-36 steel pre-cut and pre-finished with ribs running with the slope of the roof
- Trim and fascia shall be 24 gauge pre-finished to match roofing
- Trim shall be 24 gauge pre-finished 1 1/2 "J" channel to match roofing
- Open or welded "C" channels, "I" beams, "S" or "Z" purlins or angle iron shall not be allowed
- There shall be provisions for (3) lights (6) electrical outlets and (1) electrical switch
- Rain Gutters and (6) downspouts
- Location to be determined by client
- Contractor to provide detailed drawings for City approval prior to construction

TOTAL BASE BID PRICE (IN WORDS AND FIGURES)

_____ Dollars & no/cents _____
(Words) (Figures)

ALTERNATES: Provide a separate, lump sum price for the following alternates:

- Alt #1 – Concrete Pad with area of 44'X24'; 4" thickness; concrete mix of 4,000 psi w/air

TOTAL ALTERNATE BID PRICE (IN WORDS AND FIGURES)

_____ Dollars & no/cents _____
(Words) (Figures)

The undersigned hereby agrees that this bid shall be good and may not be withdrawn for a period of thirty (30) **calendar days** after the scheduled closing time for receiving bids.

The undersigned hereby agrees to enter into Contract on the attached Agreement Form within fifteen (15) consecutive calendar days from the receipt of Notice of Award from the City's acceptance of this Bid, and to complete said Work within the indicated number of consecutive calendar days from the Effective Date of the Agreement, or if a Notice to Proceed is given, from the date indicated in the Notice to Proceed.

Bidder has submitted with this Bid its 5% Bid Security as required by the Instructions to Bidders. Bidder further understands that **Performance and Payment Bonds are required** and that the Bidder's failure to submit them on the forms provided and in compliance with all requirements may result in rejection of this Bid.

If this Bid is accepted and should Bidder for any reason fail to sign the Agreement within fifteen (15) consecutive calendar days as above stipulated, the Bid Security which has been made this day with the City shall, at the option of the City, be retained by the City as liquidated damage for the delay and expense caused the City, but shall not be deemed to limit the Bidder's liability for all of the City's damages; but otherwise, it shall be returned to the undersigned in accordance with the provisions set forth in the Instructions to Bidders.

The undersigned acknowledges that the City retains the option to accept or reject any bid for any reason.

Dated at _____ this ____ day of _____, 20____.

LICENSE or CERTIFICATE NUMBER, if applicable _____

FILL IN THE APPROPRIATE SIGNATURE AND INFORMATION BELOW:

IF AN INDIVIDUAL: _____ Doing Business As

Signature and Title

Name of Firm

Business Address of Bidder: _____

Telephone No. _____

IF A PARTNERSHIP:

Name of Partnership

Member of Firm

Business Address of Bidder: _____

Telephone No. _____

IF A CORPORATION:

Name of Corporation

By _____
Signature & Title

ATTEST: _____ (CORPORATE SEAL)

Business Address of Bidder: _____

Telephone No. _____

If Bidder is a Corporation, supply the following information:

State in which Incorporated: _____

Name and Address of its: President _____

Secretary _____

City of Parkville, Missouri

City Hall

8880 Clark Avenue

Parkville MO 64152

NOTICE OF AWARD

Notice is hereby given that on the _____ day of _____, 20____, the City of Parkville Missouri, acting through its duly elected and authorized Board of Aldermen, did vote to award the following described contract:

Contract/Project Number: _____

Project Description: _____

Name of Contractor: _____

Contract Amount: _____

The Board of Aldermen has authorized the Mayor to execute the City's approved form of contract, and to deliver it to the Contractor identified above for execution and return within fourteen (14) days, along with insurance certificates and endorsements and payment and performance bonds all as identified in the bid documents. Upon receipt of these documents, properly completed to the satisfaction of the City, the bid security of Contractor and any other bidders shall be returned. If you fail to execute said agreement and to furnish all bonds and insurance within fourteen (14) calendar days from the date of delivery of this notice, the City will be entitled to consider all your rights arising out of the City's acceptance of your proposal as abandoned and to award the work covered by your proposal to another, or to re-advertise the work or otherwise dispose thereof as the City may see fit.

Signature: _____ Date: _____

Name: _____

Title: _____

CITY OF PARKVILLE, MO

**AGREEMENT BETWEEN CITY OF PARKVILLE
AND CONTRACTOR
FOR
PUBLIC IMPROVEMENT OF FRIENDS OF PARKVILLE PARK SHELTER**

This agreement is made and entered into this ____ day of _____, 2017, by and between the City of Parkville, Missouri, (hereinafter the "City") and

_____ (hereinafter the "Contractor").

WITNESSETH:

WHEREAS, the City, in the manner prescribed by law, has publicly opened, examined and evaluated the Bids submitted, and as a result of this process has, in accordance with the law, determined and declared the Contractor to be the lowest and best responsible bidder for the construction of the public improvements, and has duly selected the Contractor for award of a contract therefor upon the terms and conditions set forth in this Agreement for the sum or sums stated below.

WHEREAS, the City has caused to be prepared, in accordance with the law, Notice to Bidders, Instructions to Bidders, Bid, this Agreement, General and Special Conditions, Plans, Specifications and other documents as identified below and as further defined in the General Conditions (collectively referred to as "the Contract Documents"), for the work therein described, and has approved and adopted these said Contract Documents and has caused to be published, in the manner and for the time required by law, an advertisement inviting sealed Bids for furnishing construction materials, labor, tools, equipment and transportation necessary for, and in connection with, the construction of public improvements in accordance with the terms of this Agreement; and

WHEREAS, the Contractor, in response to the advertisement, has submitted to the City, in the manner and at the time specified, a sealed Bid in accordance with the terms of this Agreement; and

WHEREAS, the City, in the manner prescribed by law, has publicly opened, examined and evaluated the Bids submitted, and as a result of this evaluation has, in accordance with the law, determined and declared the Contractor to be the lowest and best responsible bidder for the construction of the public improvements, and has duly selected the Contractor for award of a contract therefor upon the terms and conditions set forth in this Agreement for the sum or sums set forth below.

NOW, THEREFORE, in consideration of the compensation to be paid the Contractor, and of the mutual agreements herein contained, the parties hereto have agreed, and hereby agree, the City for itself and its successors and the Contractor for itself, its successors and assigns, as follows:

ARTICLE I. The Contractor will furnish at its own cost and expense all labor, tools, equipment, materials and transportation required to construct and complete the work designated, described and required by the Contract Documents, to wit:

all in accordance with the Contract Documents, on file with the City Clerk of Parkville, Missouri, all of which are as fully a part hereof as if repeated verbatim herein; all work to be done in a good, substantial and workmanlike manner to the entire satisfaction of the City, and in accordance with the laws of the City, the State of Missouri and the United States of America. All terms used herein shall have the meanings ascribed to them in the General Conditions unless otherwise specified.

ARTICLE II. The City shall pay to the Contractor for the performance of the work embraced in this Contract, and the Contractor will accept in full compensation therefor, the sum of _____ DOLLARS (\$_____) (subject to adjustment as provided by the Contract Documents) for all work covered by and included in the Contract award and designated in the foregoing Article I, payment thereof to be made in cash or its equivalent and in the manner provided in the Contract Documents.

ARTICLE III. The contractor shall commence work upon the date stated in the Notice to Proceed and will complete all work by this Contract by _____. Time is of the essence. Accordingly, liquidated damages shall be assessed against Contractor, as stipulated liquidated damages and not as a penalty, in the amount of \$100.00 for each and every calendar day the work remains incomplete over the specified completion time.

ARTICLE IV. This Agreement shall not become effective, nor shall Contractor commence any work hereunder, until the City has received, and approved, the Certificate of Insurance and Additional Insured- and Notice of Cancellation Endorsements, the fully executed Performance and Payment Bonds with Powers of Attorney, and the list of proposed Subcontractors from Contractor.

ARTICLE V. This Agreement is entered into, under and pursuant to, and is to be construed and enforceable in accordance with the laws of the State of Missouri.

ARTICLE VI: The following documents are made part of this agreement by reference:

Exhibit A	General Conditions of the Contract
Exhibit A-1	Special Conditions of the Contract
Exhibit B-1	Performance Bond
Exhibit B-2	Payment Bond
Exhibit C	List of Plans (by sheet number and date), including all addenda thereto
Exhibit D	Specifications, including all addenda thereto
Exhibit E	Contractor's Affidavit Acknowledging Federal Lobbying Activities and Conflict of Interest Prohibition
Exhibit F	Sales tax exemption documentation forms
Exhibit G	Contractor's Affidavit of Compliance with Non-Discrimination and Equal Employment Opportunity Laws
Exhibit H	Affidavit of Compliance with Safety Training Requirements (§292.675 R.S. Mo.)
Exhibit I	Affidavit of Compliance with R.S. Mo §285.530.6
Exhibit J-1	Applicable Missouri Prevailing Wage Rates
Exhibit J-2	Prevailing Wage Rate Reporting Form
Exhibit J-3	Certification of Compliance with Prevailing Wage Requirements
Exhibit K	Insurance Requirements
Exhibit L	Bill of Sale
Exhibit M	Bailment Agreement
Exhibit N	Conditional Partial Waiver of Lien and Release of Claims
Exhibit O	Conditional Final Waiver of Lien and Release of Claims

WITNESS WHEREOF, the City of Parkville, Missouri, has caused this Agreement to be executed on its behalf, thereunto duly authorized, and the said Contractor has executed this contract in the prescribed form and manner, the day and year first above written.

CITY OF PARKVILLE, MISSOURI

By: Nanette K. Johnston

Title: Mayor

ATTEST:

Melissa McChesney, City Clerk

Contractor

By _____

Title _____

(SEAL)

(If the Contract is not executed by the President of the Corporation or general partner of the partnership, please provide documentation, which authorizes the signatory to bind the corporation or partnership. If a corporation, Contractor shall furnish the City a current certificate of good standing, dated within ten (10) days of the date of this Contract.)

EXHIBIT A
GENERAL CONDITIONS
OF THE CONTRACT FOR CONSTRUCTION

GC-1. DEFINITIONS

1. "Allowance" shall mean an item of the Work which has not been fully detailed as of the date of this Contract, and for which the City has instructed the Contractor to include a budgeted amount of money in the Contract Price, subject to reconciliation at a later time.
2. The "Bonds" shall mean the bid, performance and payment bonds, together with such other instruments of security as may be required by the Contract Documents. The forms on which Bonds must be furnished are attached to the Contract as **Exhibits B-1 and B-2**.
3. "Change Order" is a written order issued after the Contract is executed by which the City, the City Public Works Director and the Contractor agree to modifications to the Work which may result in additions or deletions to the Contract Price or Contract Time. Change Orders must be signed by the City and the Contractor to be binding.
4. "City" shall mean the City of Parkville, Missouri.
5. "City Public Works Director" shall mean the individual designated in the Contract Documents who has been employed by the City for the performance of professional services in connection with the Project.
6. The "Contract Documents" consist of (1) the Contract between the City and the Contractor (sometimes referred to herein as the "Contract"); (2) these General Conditions; (3) the Special Conditions (if any); (4) the plans; (5) the specifications; (6) all addenda issued prior to, and all modifications issued after, execution of the Contract (drawings and data which may be furnished by the Contractor and approved by the City, additional drawings which may be furnished by the Public Works Director which the City Public Works Director deems necessary to make clear the intent of the Contract Documents (and, in particular, the specifications), and the bidding documents. It is understood that the Work shall be carried out and the Project shall be constructed fully in accordance with the Contract Documents.

7. "Contract Price" shall be the amount identified in the Contract between City and Contractor as the total amount due to the Contractor for total completion of the Work as per the Contract Documents.
8. The "Contract Time" shall be the number of calendar days for completion of the Work, or a specified date by which the Work shall be completed, as stated in the Contract.
9. "Defective Work" shall mean Work which is unsatisfactory, faulty or deficient or not in conformity with the Contract Documents. It shall also include Work damaged prior to approval of final payment, unless responsibility for such damage shall have been expressly assumed by the City at Substantial Completion.
10. "Effective Date of the Contract" shall mean the date indicated in the Contract on which it becomes effective, but, if no such date is indicated, it shall mean the date on which the Contract is signed and delivered by the City to the Contractor.
11. "Final Acceptance" shall mean the date when the City Public Works Director accepts in writing that the construction of the Project is complete in accordance with the Contract Documents such that the entire Project can be utilized for the purposes for which it is intended; that all other obligations of the Contractor have been satisfied; and that the Contractor is entitled to final payment.
12. "Inspector" shall mean the person or firm authorized in writing by the City Public Works Director or the City to perform inspections of the Work as provided in the Contract Documents.
13. "Modification" shall mean a written amendment to the Contract signed by both parties changing its terms, including but not limited to Change Orders, written interpretations issued by the City Public Works Director, and written orders for minor changes in the Work issued by the City Public Works Director.
14. "Notice to Proceed" shall mean the written notice issued by the City to the Contractor fixing the date on which the Contract Time is to commence and on which the Contractor shall start to perform its obligations under the Contract Documents.
15. "Partial Occupancy" shall mean placing a portion of the Work to be provided under the Contract Documents to the use intended by the City.
16. "Plans" shall mean and include all drawings which may have been or may be furnished by the City to Contractor for use in performing the Work. The Plans, including all addenda thereto, are more specifically identified on **Exhibit C**.

17. "Prevailing Wages" shall mean those wages included in the Prevailing Wage Order issued by the State of Missouri that is included as an Exhibit **J-1** to the Contract.
18. "Shop Drawings" shall mean all drawings, diagrams, illustrations, brochures, standard schedules, performance charts, instructions, diagrams and other information and data which are submitted by the Contractor, a Subcontractor, manufacturer, fabricator, supplier or distributor to illustrate some portion of the Work as required by the Contract Documents.
19. "Specifications" shall mean those portions of the Contract Documents consisting of written technical descriptions of materials, equipment, construction methods, standards and workmanship as applied to the Work and certain administrative details applicable thereto. The Specifications, including all addenda thereto, are more specifically identified on **Exhibit D**.
20. "Subcontractor" shall mean an individual, firm or corporation having a direct contract with the Contractor or with another subcontractor for the performance of a part of the Work.
21. "Submittals" shall mean any Shop Drawing, sample or other physical or electronic information concerning a material, equipment, method of installation or other descriptive data required by the Contract Documents to be submitted by the Contractor.
22. "Substantial Completion" shall mean the state of the Project when the Work, or a designated portion thereof, is sufficiently complete in accordance with the Contract Documents, so that the City can occupy or utilize the Work or the designated portion thereof for its intended purpose.
23. "Underground Facilities" shall mean all pipelines, conduits, ducts, cables, wires, manholes, vaults, tanks, tunnels or other such facilities or attachments, and any encasements containing such facilities which have been installed underground to furnish services or materials including, but not limited to, electricity, gases, steam, liquid petroleum products, telephone or other communications, cable television, sewage and drainage removal, traffic or other control systems or water.
24. The "Work" shall mean everything required of the Contractor by the Contract Documents to complete the construction, and includes all construction, labor, materials, tools, equipment and transportation and other items reasonably inferable from the Contract Documents for a fully functional end product.
25. "Work Directive" shall mean a written order from the City Public Works Director to the Contractor to proceed with Work in the manner specified, despite disagreement between the City and the Contractor as to whether the contents of

the directive constitute a change to the Contract Documents, or the appropriate adjustment, if any, in the Contract Time or Contract Price as a result.

GC-2. SCOPE, NATURE AND INTENT OF THE CONTRACT DOCUMENTS

1. The Contract Documents as enumerated herein form the Contract for construction. The Contract Documents are complementary, but not necessarily duplicate each other, and what is called for by any one shall be as binding as if called for by all. The intention of the Contract Documents is to include all construction, labor, materials, tools, equipment and transportation necessary for the workmanlike construction of the Project in accordance with the Contract Documents.
2. Dimensions and elevations shown on the Plans shall be accurately followed, even though they may differ from scaled measurements. All Work performed under this Contract shall be done to the lines, grades, and elevations shown on the Plans. No work shown on the Plans, the dimensions of which are not indicated, shall be executed until the required dimensions have been obtained from the City Public Works Director. Contractor shall be responsible for verification of all locations, dimensions and elevations in the field (including, but not limited to verification of location of Underground Facilities and utilities) and shall verify all field dimensions shown on the Contract Documents.
3. The Contractor shall keep the City Public Works Director informed a reasonable time in advance of the times and places at which he wishes to do Work, in order that lines and grades may be furnished and necessary measurements for record and payment may be made with the minimum of inconvenience and delay to the City Public Works Director and the Contractor.
4. Any Work done without being properly located and established by base lines, offset stakes, bench marks, or other basic reference points may be ordered removed and replaced at the Contractor's cost and expense. Contractor shall notify all affected utilities of the Work and coordinate with the utilities to avoid interruption of utility service and damage to utility lines and property. This notice requirement shall also apply as to the owner/operator of any affected Underground Facility. Any project delay, damages or increase in construction costs due to utility relocation delays shall be the Contractor's responsibility.
5. Contractor, together with its Subcontractors, shall carefully examine the Contract Documents for any interferences with the Work and clearances that may be required. Contractor shall be responsible for the proper fitting of materials and equipment without substantial alterations. Contractor shall be responsible for eliminating interferences without additional cost to City. If departures from the Plans and Specifications, or other Contract Documents, are deemed necessary by Contractor, details of such departures and reasons therefor shall be submitted

to City Public Works Director, with drawings (if City Public Works Director determines that drawings are necessary), for approval as soon as practical. No such departure shall be made except at the peril of the Contractor without the prior written approval of the City Public Works Director.

6. Whenever any word or expression defined herein, or pronoun used in its stead, occurs in these Contract Documents; it shall have and is mutually understood to have the meaning herein given. Work described in words which so applied have a well-known technical or trade meaning shall be held to refer to such recognized standards.
7. Whenever in these Contract Documents the words "as ordered," "as directed," "as required", "as permitted", "as allowed," or words or phrases of like import are used, it is understood that the order, direction, requirement, permission or allowance of the City and/or the City Public Works Director is intended.
8. Whenever any statement is made in the Contract Documents containing the expression "it is understood and agreed," or an expression of like import, such expression means the mutual understanding and agreement of the parties hereto.
9. The words "approved," "reasonable," "suitable," "acceptable," "properly," "satisfactory," or words of like effect in import, unless otherwise particularly specified herein, shall mean to the reasonable satisfaction of the City.
10. Titles and subheadings as used herein and other Contract Documents are provided only as a matter of convenience and shall have no legal bearing on the interpretation of any provision of the Contract Documents.
11. Discrepancies or conflicts among the Contract Documents shall be resolved in the following order of priority:
 - a. Modifications to the Contract
 - b. The Contract
 - c. Special Conditions
 - d. General Conditions
 - e. Plans
 - f. Specifications
12. This Contract, together with the other Contract Documents, constitutes the entire agreement between the parties and supersedes all prior agreements, whether oral or written, covering the same subject matter.

13. The Contract may not be amended or modified except by a modification as hereinabove defined.

14. It is specifically agreed between the parties executing this Contract that the Contract Documents are not intended to create any third party beneficiary relationship nor authorize anyone not a party to this Contract to maintain a suit for personal injuries or property damage pursuant to the terms or provisions of this Contract. The duties, obligations and responsibilities of the parties to this Contract with respect to third parties shall remain as imposed by law.

GC-3. DEFECTS IN CONTRACT DOCUMENTS

If Contractor has reasonable cause such that it should, in the exercise of ordinary care of someone in its position, know that any errors, omissions, ambiguity, discrepancies or inconsistencies (hereinafter "defects") appear in the Contract Documents, including but not limited to, the plans, specifications and other documents or the Work, Contractor shall notify the City Public Works Director in writing of such defects prior to taking any action in reliance on any of them. Contractor shall abide by the City Public Works Director's clarification without any increase in the cost of the Work. Subcontractors and remote tier Subcontractors shall, likewise, notify the Contractor in writing of any defects therein, and it shall be the obligation of the Contractor to remedy same as if Contractor had discovered such defects itself. The Contractor will not be permitted to take advantage of any such defect.

GC-4. COPIES OF THE CONTRACT

1. Unless otherwise provided in the Contract Documents, City will furnish to Contractor a maximum of two (2) copies of the Contract Documents, free of charge, necessary for the execution of the Work.
2. Contract Documents are the property of the City, and none of the Contract Documents are to be used on other work by Contractor. At City's request, all Contract Documents shall be returned to the City with the exception of one record set for the Contractor. All models and calculations are the property of City.
3. Contractor shall keep, and make available to City, at the Project site, one copy of all Contract Documents for the Work at the Project site, in good order and legibly marked to reflect actual construction, in hard-copy or electronic form as specified in the Contract Documents. Contractor shall also maintain at the site all approved samples and a print of all approved Shop Drawings.
4. Such Documents, samples and Shop Drawings and record drawings reflecting the work as-built shall be turned over to the City at the completion of the Work if requested by the City.

GC-5. SCOPE OF WORK AND GENERAL ADMINISTRATION OF THE CONTRACT

1. Unless otherwise stipulated, Contractor shall provide and pay for all Work (including labor, transportation, tools, equipment, machinery, plant and appliances) necessary to produce the results called for by the Contract Documents.
2. The Contractor shall be solely responsible for and have complete control and charge of construction means, methods, techniques, sequences and procedures, and for safety precautions and programs in connection with the Work. Neither the City nor the City Public Works Director shall be responsible for nor have control or charge over the acts or omissions of the Contractor, Subcontractors, or any of their agents or employees, or any other persons performing any of the Work.
3. In executing the Contract, the Contractor expressly covenants and agrees that, in the undertaking to complete the Work within the time therein fixed, it has taken into consideration and made allowances for all hindrances and delays incident to such Work, whether growing out of delays in securing materials, workers, and typical weather conditions or otherwise. No charge shall be made by the Contractor for hindrances or delays from any cause during the progress of the Work, or any portion thereof, included in this Contract, except as provided elsewhere herein.
4. The Contractor shall comply with all City, County, State and Federal laws, ordinances or regulations which would in any way control the actions or operations of those engaged in the work under this Contract or which would affect the materials supplied to or by them. It shall at all times observe and comply with all ordinances, laws and regulations and shall protect and indemnify and defend the City and the City's officers and agents against any claims or liability arising from or based on any violation of same. Because the Project may involve federal funds, Contractor shall execute the affidavit attached to the Contract as **Exhibit E**, confirming its compliance with the prohibition against federal lobbying and conflicts of interest.
4. It is understood that all royalties and fees for and in connection with patents, or patent infringement, claims for materials, articles, apparatus, devices or equipment used in or furnished for the Work shall be included in the Contract Price. Final payment to the Contractor by the City shall not be made while any suit or claim involving infringement or alleged infringement of any patent remains unsettled.
5. The Contractor shall, in addition to the schedule required by these General Conditions, give to the City Public Works Director full information in advance as to its plans for carrying on any part of the Work. If at any time before the beginning or during the progress of the Work, any part of the Contractor's plant or

equipment or any of its methods of executing the Work, appear to the City Public Works Director to be unsafe, inefficient or inadequate to ensure the required quality or rate of progress of the Work, the City Public Works Director may order the Contractor to increase or improve its facilities or methods, and the Contractor shall promptly comply with such orders; but neither compliance with such orders nor failure of the City Public Works Director to issue such orders shall relieve the Contractor from its obligation to secure the degree of safety, the quality of Work and the rate of progress required by the Contract.

6. The approval by the City Public Works Director of any plan, schedule or method of Work proposed by the Contractor shall not relieve the Contractor of any responsibility therefor, and such approval shall not be considered as an assumption by the City, or any officer, agent or employee thereof, of any risk or liability, and the Contractor shall have no claim under this Contract on account of the failure or inefficiency of any plan or method so approved. Such approval shall be considered and shall mean that the City Public Works Director has no objection to the Contractor's use or adoption, at the Contractor's own risk and responsibility, of the plan or method so proposed by the Contractor.
7. It is the intent of the City to supply the Contractor with a Sales and Use Tax Exemption certificate for use in purchasing materials and supplies on the Project. This documentation, a copy of which form is attached as Exhibit "F," must be signed and returned to the City upon completion of the Project.

GC-6 ALLOWANCES

1. The Contractor shall include in the Contract Price all allowances stated in the Contract Documents. Items covered by allowances shall be supplied for such amounts and by such persons or entities as the City may direct, but the Contractor shall not be required to employ persons or entities to whom the Contractor has reasonable objection. No demand for expenses or overhead and fee for Allowance items other than those included in the Contract Price shall be allowed.
2. Unless otherwise provided in the Contract Documents,
 - (a) allowances shall cover the cost to the Contractor of materials and equipment delivered at the site and all required taxes, less applicable trade discounts;
 - (b) Contractor's costs for unloading and handling at the site, labor, installation costs, overhead, profit and other expenses contemplated for stated allowance amounts shall be included in the Contract Sum but not in the allowances; and
 - (c) whenever costs are more than or less than allowances, the Contract Price shall be adjusted accordingly by Change Order. The amount of the Change

Order shall reflect (1) the difference between actual costs and the allowances and (2) changes in Contractor's costs.

3. Materials and equipment under an allowance shall be selected by the City with reasonable promptness.

GC-7. AUTHORITY AND DUTY OF THE CITY PUBLIC WORKS DIRECTOR

The City Public Works Director is authorized to observe and inspect all Work included herein. Anything in the Contract Documents to the contrary notwithstanding, the City Public Works Director shall in all cases

- (a) determine the amount and quantities of the several kinds of Work which are to be paid for under this Contract;
- (b) rule on all questions relating to the plans and specifications for the Project;
- (c) issue written clarifications or interpretations of the requirements of the Contract Documents (in the form of drawings or otherwise) which City Public Works Director may determine are necessary, which shall be consistent with or reasonably inferable from the overall intent of the Contract Documents;

The City Public Works Director's decisions and findings shall be a condition precedent to the right of the parties to pursue disputes as otherwise provided herein. It is the intent of the Contract that there shall be no delay in the execution of the Work, and the decisions or directions of the City Public Works Director as rendered shall be promptly carried out.

GC-8. SUPERINTENDENCE AND SUPERVISION

1. Contractor shall provide all necessary supervision to the Work using its best skill, care, judgment and attention and shall keep on the Work, during its progress, a competent superintendent, and any necessary assistants, all satisfactory to City Public Works Director. The superintendent shall not be changed except with the consent of the City Public Works Director unless the superintendent proves to be unsatisfactory to the Contractor and/or ceases to be in its employ; provided however, that the City Public Works Director retains the right to require that the Contractor replace the superintendent at any time, such right not to be arbitrarily exercised.
2. Contractor shall furnish the City Public Works Director with the superintendent's cellphone and pager numbers and email address, and assure that the

superintendent is readily available to respond to calls and emails during business hours and, in emergency situations, outside of business hours.

3. Unless otherwise authorized in writing by the City Public Works Director, no Work shall be performed except when the superintendent is on-site. Contractor's superintendent shall be fluent in all languages necessary to communicate with the City, the City Public Works Director, Contractor's employees and Contractor's Subcontractors, for efficient administration, communication and safety.
4. The superintendent shall be fully authorized to act for the Contractor and receive whatever orders as may be given for the proper prosecution of the Work or notices in connection therewith. The superintendent must attend all meetings to represent Contractor and shall be informed sufficiently to adequately communicate on behalf of Contractor.
5. Use of Subcontractors on portions of the Work shall not relieve the Contractor of its obligation to have a competent superintendent directly employed by the Contractor on the Work at all times.

GC-9. CONTRACTOR'S EMPLOYEES

1. Contractor shall only engage employees who are competent to perform the Work assigned, and if the City Public Works Director so directs, Contractor shall promptly remove any employee determined by the City Public Works Director to be unacceptable. Contractor shall perform appropriate screening of candidates to assure their capability and suitability for the Work.
2. Contractor shall at all times enforce strict discipline and good order among its employees and shall not employ on the Work any unfit person or anyone not skilled in the Work assigned to him.
3. Contractor shall be responsible for compliance with all state and federal laws, if applicable, pertaining to wages, hours and benefits for workers employed to carry out the Work.
4. Contractor shall execute, and shall require all Subcontractors to execute, the affidavit which is attached to the Contract as **Exhibit G** relating to equal employment opportunity and non-discrimination.
5. **Missouri Safety Training Requirements** Contractor and all subcontractors shall provide a 10-hour OSHA construction safety program or similar program approved by the Missouri Department of Labor and Industrial Relations, to be completed on site by all employees within sixty (60) days of beginning work on the Project, pursuant to Section 292.675, Revised Statutes of Missouri. Contractor, or any subcontractors in violation of this requirement, will forfeit to the

City the sum of \$2,500 plus \$100 per day for each employee without training. The City may withhold penalties from the payment due to Contractor and its subcontractors. To assure compliance with this requirement, Contractor and all its subcontractors shall be required to execute an affidavit on the form attached hereto as **Exhibit H**.

6. **Missouri Immigration Compliance Requirements.** Contractor shall be responsible for ensuring compliance with the Immigration Reform Act of 1986 and all laws regulating immigration and the verification of eligibility for employment of persons. Contractor shall verify that its employees are eligible for employment and keep records of such verification for the periods prescribed by the Immigration Reform Act of 1986. Effective January 1, 2009, all contractors and subcontractors with contract amounts in excess of Five Thousand Dollars (\$5,000) on public projects in Missouri are required to verify the employment eligibility status of employees through the E-verify federal program administered by the Department of Homeland Security, U.S. Citizenship and Immigration Services. Contractor shall indemnify, defend and hold harmless the City against any expense incurred including imposition of fines which results from violation of such laws. Contractor affirmatively states that it is not knowingly in violation of R. S. Mo. 285.530.1 and shall not henceforth be in such violation. Contractor further agrees to execute the sworn affidavit, attached hereto as **Exhibit I**, under the penalty of perjury attesting to the fact that Contractor's employees are lawfully present in the United States. Contractor shall obtain a similarly executed affidavit from all subcontractors and sub-subcontractors with contract amounts of \$5,000 or more. Failure of Contractor to comply with this requirement shall be grounds for termination for default.

7. Prevailing Wage Requirements

- (a) All of the Work performed under this Contract is subject to the requirements of Section 290.210-.340, Revised Statutes of Missouri, requiring payment of not less than the Prevailing Wages for Platte County, Missouri, and of Title 8, Division 30, Chapter 3, of the Code of State Regulations (the "Prevailing Wage Requirements"). Attached to this Contract as **Exhibit J-1** is the Prevailing Wage Order applicable to this Contract. Contractor agrees to comply with all Prevailing Wage Requirements with regard to Prevailing Wages, including but not limited to, maintaining and submitting full and accurate payroll records as required by Section 290.290.1, RSMo. and 8 CSR 3-30.010 et seq.
- (b) Contractor shall create, maintain and submit, and shall require each of its Subcontractors to create, maintain and submit on a weekly basis, a Certified Payroll Report form, the format to be of the Contractor's own choosing which contains, at minimum, the information described on **Exhibit J-2**, indicating each worker's name, address, social security number, occupational title, hours worked, and wages paid of every worker employed in connection with

this Contract. Each payroll must be accompanied by a Certification Form substantially similar to **Exhibit J-3** indicating the accuracy and authenticity of such records, and signed by the Contractor's or Subcontractor's representative, attesting to the completeness and accuracy of the data on the Certified Payrolls. Contractor shall also post notices and identify its vehicles as provided by the Prevailing Wage Requirements.

- (c) Contractor further agrees to indemnify, defend and hold harmless the City from and against any claim, liability, assessment, fine, penalty or other cost, including attorney's fees, which may be asserted against or incurred by the City as a result of an allegation that Contractor has not complied with these Prevailing Wage Requirements, whether such claim is asserted by a worker or by the Division of Labor Standards or any other entity. This indemnification shall survive termination of this Contract

8. No illegal drug, alcohol, or firearm usage will be tolerated at the Site. All persons admitted to work on the Site will dress appropriately and avoid foul language. Music shall not be played at volume levels that would be objectionable to third-parties. Any worker found by the City to be violating these conduct requirements will be removed immediately.

GC-10. WORK STOPPAGES

Contractor warrants to the City that there shall be no work stoppages or interruptions arising out of labor disputes, including, but not limited to, those due to the presence of both union and non-union workforces at the job site. The City may assign to Contractor a separate gate (e.g., union or non-union gate, as applicable). The gate assigned shall be used by Contractor and all Contractor's employees, Subcontractors, visitors, suppliers, vendors and materials deliveries, as applicable. Contractor agrees that Contractor's employees and its Subcontractor's employees will continue to work notwithstanding any dispute that may involve any other contractor or employer at the job site. Anything in this Contract to the contrary notwithstanding, in the event the Contractor fails to continue performance of the Work included herein without interruption or delay, because of such picket or other form of labor dispute, the City may terminate the services of said Contractor after giving 48 hours written notice to Contractor and its sureties of its intent to do so, or the City may invoke any of the rights set forth elsewhere in the Contract Documents.

GC-11. BEGINNING, PROGRESS AND TIME OF COMPLETION OF WORK

1. The Contractor shall, within the time set forth in the Notice to Proceed, or if no time is stated, within ten (10) days after being instructed to do so in the written "Notice to Proceed" from the City, commence the Work to be done under this Contract; and the rate of progress shall be such that the Work shall have been completed in accordance with the terms of the Contract on or before the

termination of the construction period contractually specified, subject to any extensions of such time made as hereinafter provided. Without the prior express written consent of the City, Contractor shall do no Work until the date set forth in the Notice to Proceed.

2. The Contractor, promptly after being awarded the Contract, shall prepare and submit for the City Public Works Director's information before submission of Contractor's first request for payment, a Contractor's construction schedule for the Work. If the City Public Works Director so requests, the Contractor shall submit the schedule in an electronic format such as Primavera or other commonly utilized software program. The schedule shall not exceed time limits current under the Contract Documents; shall be revised at appropriate intervals as required by the conditions of the Work and Project; shall be related to the entire Project to the extent required by the Contract Documents; shall be coordinated with applicable Subcontractors; and shall provide for expeditious and practicable execution of the Work. Schedules of subcontractors will also be available for inspection. The Work will be performed in accordance with the most current Schedule.
3. The Contractor shall be responsible for revisions to schedules of and coordinating same with its Subcontractors, and will resolve conflicts among their schedules.
4. Night Work may be established by the Contractor, as a regular procedure, with the written permission of the City Public Works Director; such permission, however, may be revoked at any time by the City Public Works Director. Otherwise, no Work shall be done between the hours of 6:00 p.m. and 7:00 a.m., nor on weekends or City holidays, without the written approval or permission of the City Public Works Director 48 hours in advance in each case, except such Work as may be necessary for the proper care, maintenance and protection of Work already done or of equipment, or in the case of an emergency jeopardizing persons or property.
5. **All limits stated in the Contract Documents are of the essence of the Contract.**

GC-12. LIQUIDATED DAMAGES

1. It is mutually understood and agreed by and between the parties to this Contract that in the event that the Contractor shall fail in the performance of the Work specified and required to be performed within the period of time stipulated therefor in the Contract, the City will be damaged in an amount which is difficult to ascertain with certainty at this time. Therefore, the parties agree, as a representation and fair allocation of risk and not as a penalty, that after due allowance for any extension or extensions of time which may be granted under

the Contract, if the Contractor is responsible for delay in Substantial Completion of the Work, the Contractor shall pay to City, or the City may withhold from the Contractor, as stipulated liquidated damages and not as a penalty, the sum stated in the Contract for each 24-hour calendar day, including weekends and holiday that Substantial Completion is not attained.

2. In the case of joint responsibility for any delay in the final completion of the work covered by this Contract, where two or more separate contracts are in force at the same time and cover work on the same Project and at the same site, the total amount of liquidated damages assessed against all contractors under such contracts, for any one day of delay in the final completion of the Work will not be greater than the approximate total of the liquidated damages sustained by the City by reason of such delay in completion of the Work, and the amount assessed against any one contractor for such one day of delay will be based upon the individual responsibility of such contractor for the aforesaid delay as determined by, and in the judgment of, the City.
3. In the event that the City elects to accept part of the Work as Substantially Complete prior to Substantial Completion of all of the Work, the parties shall equitably adjust the daily rate of liquidated damages. In the event that the parties cannot agree on such equitable adjustment, the Contractor has the right to pursue remedies under the disputes resolution procedures stated elsewhere in these General Conditions.

GC-13. INSPECTION OF WORK

1. The City, the City Public Works Director, and any third-party inspectors ("Inspector") shall at all times have access to the Work for the observation and inspection thereof wherever it is in preparation or progress, and Contractor shall provide proper facilities for such inspection. The Contractor shall comply with the directions and instructions of the Inspector. The Contractor shall furnish all reasonable aid and assistance required for any such inspection.
2. For all Work which the Contract Documents provide will be inspected, tested, or approved, the Contractor shall give the City Public Works Director timely notice of its readiness for such inspection, testing or approval and the date fixed for such inspection, testing or approval if the inspection, testing or approval is by an authority other than City Public Works Director.
3. All specified and required tests for approval of material shall be made at the expense of the Contractor by a properly equipped laboratory of established reputation, whose work and testing facilities shall be approved by the City Public Works Director. Approval of materials based on acceptable tests will apply only while such materials as furnished equal or exceed the tested samples or test specimens in quality and minimum requirements. Any change in origin, method

of preparation or manufacture of such materials will require new test and approval thereof. Reports of all tests shall be furnished to the City Public Works Director in as many certified counterparts as may be required by the City Public Works Director.

4. If Work is found not to be in accordance with the Contract Documents, Contractor shall at his own expense bear the cost of uncovering such Work, the cost of removing same, as well as the cost of undoing and redoing the Work and other Work damaged by such nonconforming Work.
5. The City reserves the right to require inspection of any and all Work before it is covered up; and, accordingly, Contractor must notify the City Public Works Director before covering any Work. If any Work should be covered up which is required to be inspected, tested or approved and which, by virtue of being covered up, is not susceptible to being properly inspected, tested or approved, Contractor shall, if requested by Inspector, uncover such Work and bear the thereof, and of redoing same after inspection, testing or approval and redoing such other Work damaged as a result of having to uncover and redo same.
6. The Inspector shall be free at all times to perform its duties, including the observation and inspection of the Work, and intimidation or attempted intimidation of any one of them by the Contractor or by any of its employees shall be sufficient reason, if the City so desires, to terminate the Contract.
7. Any inspection, by whomsoever conducted, shall not relieve the Contractor from any obligation to perform the Work strictly in accordance with the plans and specifications, and any of the Work not so constructed shall be removed and made good by the Contractor at its own expense.

GC-14. CONCEALED CONDITIONS

1. The City makes no warranty, express or implied, that the various and sundry materials and information, including, by way of example and without limitation, soil tests, bore reports, utility locations and other such data and as-builts in the case of renovation of or addition to existing facilities, reflect actual conditions. The Contractor represents and warrants that it has examined the site and conducted such tests and examinations as it deems necessary and assumes all responsibility for the foregoing. That being the case, should the Contractor encounter (1) concealed conditions of a nature which of an unusual nature, differing materially from those ordinarily encountered or generally recognized as inherent in Work of the character provided for in this Contract; or (2) conditions which are at variance with the conditions indicated by the Contract Documents, or should unknown physical conditions below the surface of the ground, or should concealed or unknown conditions in an existing structure, be encountered, the Contract Time and/or Contract Price may be equitably adjusted

by the City upon recommendation by the City Public Works Director. No such adjustment will be made unless the Contractor brings the matter to the City Public Works Director's attention within 48 hours of first encountering the condition, and unless the condition actually interfered with the critical path of Contractor's work.

2. Discovered Artifacts. If, in the course of the Work, the Contractor encounters human remains or recognizes the existence of burial markers, archaeological sites or wetlands not indicated in the Contract Documents, the Contractor shall immediately suspend any operations that would affect them and shall notify the City Public Works Director. Upon receipt of such notice, the City Public Works Director shall promptly take any action necessary to obtain governmental authorization required to resume the operations. The Contractor shall continue to suspend such operations until otherwise instructed by the City Public Works Director but shall continue with all other operations that do not affect those remains or features. Requests for adjustments in the Contract Sum and Contract Time arising from the existence of such remains or features may be made as provided in this Contract.

GC-15. SUBMITTALS.

1. The Contractor shall prepare a submittal schedule, promptly after being awarded the Contract and thereafter as necessary to maintain a current submittal schedule, and shall submit the schedule(s) for the City Public Works Director's approval. The submittal schedule shall (1) be coordinated with the Contractor's construction schedule, and (2) allow the City Public Works Director time to review submittals. If the Contractor fails to submit a submittal schedule, the Contractor shall not be entitled to any increase in Contract Sum or extension of Contract Time based on the time required for review of submittals.
2. Contractor shall submit, with such promptness as to cause no delay in his own work or in that of any Subcontractor or other contractor, three (3) copies of all shop, fabrication, assembly, foundation and other drawings and schedules, samples, certifications or other documentation or thing required by the specifications, including, but not limited: (1) drawings of equipment and devices offered by the Contractor for approval of the City Public Works Director in sufficient detail to adequately show the construction and operation thereof; (2) drawings showing essential details of any change in design of construction proposed, for consideration by the City Public Works Director, by the contractor in lieu of the design or arrangement required by the Contract Documents, or any item of extra work thereunder; (3) all required wiring and piping layouts; (4) samples of products representative of color, finish or other characteristics as stated in the specifications; and (5) structural and reinforcing fabrication drawings. At the option of the Director of Public Works, such information may be submitted electronically.

3. The City Public Works Director shall review, respond to, accept or reject such submittals within a reasonable time after receipt thereof. Contractor shall make such revisions as deemed necessary. Failure of the City Public Works Director to reject a submittal shall not operate as acceptance, or relieve Contractor of responsibility for compliance with the Contract Documents.
4. Once the Submittal is in a form acceptable to the City Public Works Director, the Contractor shall furnish a total of not less than three (3) copies of the final Submittal, and more when required, of each drawing as finally approved, such number to include any copies of preliminary or revised drawings which are approved as submitted. After due review by the City Public Works Director, all such drawings shall become a part of the Contract Documents, and the Work or equipment shown by such drawings shall be in conformity with said drawings unless otherwise required by the City Public Works Director.
5. No Work shall be performed in connection with the fabrication or manufacture of material or equipment shown by any drawing thereof, nor shall any accessory, appurtenance or device not fabricated or manufactured by the Contractor or its Subcontractors be purchased, until the drawing or drawings therefor have been approved as stipulated, except at the Contractor's own risk and responsibility. Review for compliance by the City or the City Public Works Director of drawings or other items submitted by Contractor shall not relieve Contractor from responsibility for errors of any sort in Shop Drawings or other submittals.

GC-16. WARRANTY

1. Contractor warrants to the City that materials and equipment furnished under the Contract will be of good quality and new unless the Contract Documents require or permit otherwise. The Contractor further warrants that the Work will conform to the requirements of the Contract Documents and will be free from defects, except for those inherent in the quality of the Work the Contract Documents permit or require. Work, materials, or equipment not conforming to these requirements may be considered defective. The Contractor's warranty excludes remedy for damage or defect caused by abuse, alterations to the Work not executed by the Contractor, improper or insufficient maintenance, improper operations, or normal wear and tear and normal usage. If required by the City Public Works Director, the Contractor shall furnish satisfactory evidence as to the kind and quality of materials and equipment.
2. Should any special or specific warranties be required by any part of the Contract Documents, they shall be in addition to and not in place of the warranty of this paragraph. All manufacturer's warranties shall be assignable, and assigned to, the City.

3. Contractor shall require a similar warranty from each Subcontractor for all Work performed by such Subcontractor, which shall run to the benefit of the City. All such warranties shall be in writing and shall be promptly delivered to City. The furnishing of such warranties by Subcontractors and materialmen, however, shall not relieve Contractor of his obligations under this section. At the City's sole option, Contractor shall assign to City any rights Contractor may have against any Subcontractor and/or supplier for defective Work, materials or equipment.
4. Any provision of the Contract Documents to the contrary notwithstanding, all warranties provided for in the Contract Documents shall begin to run from the date of final payment by City to Contractor.

GC-17. APPROVAL OF EQUALS; REQUESTS FOR SUBSTITUTIONS

1. Approved equals, where permitted by the Contract Documents or otherwise made feasible by market conditions, shall be considered for approval as follows:
 - (a) Contractor shall notify City in writing if it wishes to use an alternative product, and if such was specifically named in the Contract Documents.
 - (b) If Contractor desires to use a product not specifically named in the Contract Documents, it must first inform City and receive written approval for such substitutions. City has no obligation to approve such request and is not responsible for any delay or cost incurred or caused by Contractor's making such request.
2. After this Contract has become effective, the City Public Works Director will consider a request for a substitution of products in place of those specified upon advance written request by Contractor. By making a request for a substitution, and unless otherwise specifically agreed to in writing by the City, Contractor represents that:
 - (a) Contractor has personally investigated the proposed substitute product and determined that it is equal or superior in all respects to that specified;
 - (b) Contractor will endeavor to provide at least as extensive a warranty for the substituted product as for the originally specified product. If it cannot obtain as broad a warranty for the product offered, the lesser warranty will be specifically disclosed in the request for substitution; and
 - (c) Contractor will coordinate the installation of the accepted substitute, making such adjustments as may be required for the Work to be complete in all respects.

3. The Contractor shall be solely responsible for design risks, delays and other claims arising out of any approved alternates or substitutions.
4. All specified and required tests for approval of material proposed as "equal" or as a substitution shall be made at the expense of the Contractor by a properly equipped laboratory of established reputation, whose work and testing facilities shall be approved by the City Public Works Director. Approval of materials based on acceptable tests will apply only while such materials as furnished equal or exceed the tested samples or test specimens in quality and minimum requirements. Any change in origin, method of preparation or manufacture of such materials will require new test and approval thereof. Reports of all tests shall be furnished to the City Public Works Director in as many certified counterparts as may be required by the City Public Works Director.

GC-18. PERMITS AND NOTICES

1. All permits and licenses shall be secured and paid for by Contractor, unless otherwise specified.
2. Contractor shall give all notices required by and all Work shall be done in accordance with all applicable federal and state laws, City and County laws and ordinances, building codes and rules and regulations bearing on the conduct of the Work.

GC-19. USE OF PREMISES

1. Contractor shall confine its operations to limits indicated by law, ordinances, rules, regulations, and permits of City or directions of City Public Works Director and shall not unreasonably encumber the premises and/or site.
2. Contractor shall not load or permit any part of any structure, street or highways to be loaded with a weight that exceeds load limits which that will endanger their safety.
3. Contractor shall comply with federal, state and local laws and ordinances, as well as any specific instructions regarding signs, advertisements, fires and smoking from City Public Works Director.
4. If provided in the Contract Documents, a laydown area or staging area shall be chosen by City Public Works Director. Contractor will furnish its own weather protection for materials, equipment and work in progress if required.
5. No City equipment will be taken out of service or put into service without approval of City.

GC-20. PROTECTION OF WORK AND PROPERTY

1. Contractor shall maintain at all times, as required by the conditions and progress of the Work, all necessary safeguards for the protection of life, the Work, supplies, materials and equipment on the Project site not yet incorporated in the Work, City's property and adjacent property. Contractor shall be solely liable for all damages to the City or the property of the City, to employees of the City or other contractors, to neighboring premises, or to any private or personal property, due to improper, illegal or negligent conduct of the Contractor, its Subcontractors, employees or agents in and about said Work, or in the execution of the Work. The Contractor shall be liable to the City for any damages, whether property damage or personal injury, occasioned by Contractor's use of any scaffolding, shoring, apparatus, ways, works, machinery, plant or any other process or thing that is required for the Work.
2. The Contractor shall give reasonable notice to the affected owners and utilities when any such property is liable to injury or damage through the performance of the Work and shall make all necessary arrangements with such owner or owners relative to the removal and replacement or protection of such property and/or utilities.
3. The Contractor shall satisfactorily shore, support and protect any and all structures and all excavations, pipes, sewers, drains, conduits and other Underground Facilities and shall be responsible for any damage resulting thereto. The Contractor shall not be entitled to any additional Contract Time on account of any postponement, interference or delay caused by any such structures and facilities being on the line of the Work, whether they are shown on the plans or not.
4. During unfavorable weather, or other unfavorable conditions for construction operations, the Contractor shall pursue only such portions of the Work as will not be damaged thereby. No portions of the Work, the satisfactory quality or efficiency of which will be affected by any unfavorable conditions, shall be constructed while these conditions exist, unless, by special means or precautions approved by the City Public Works Director, the Contractor shall be able to perform the Work in a proper and satisfactory manner.
5. The Contractor shall assume full responsibility for the Work and shall bear any loss and repair any damage at his/her own cost occasioned by neglect, accident, vandalism or natural cause, whether foreseen or unforeseen, during the progress of the Work and until the Work is completed and accepted by the City.
6. Contractor shall comply with any and all instructions from the City Public Works Director regarding prevention of accidents, fires or for the elimination of any unsafe practice and shall observe all the applicable recommendations of the

National Fire Protection Association Standard No. 241 (or other, later revision) "Standards For Safeguarding Building Construction and Demolition Operations".

7. Contractor shall post danger signs warning against the hazards created by such features of construction as protruding nails, hod hoists, well holes, elevator hatchways, scaffolding, window openings, stairways, falling materials, open trenches, other excavations, obstructions and similar conditions. All open trenches and other excavations shall be provided with suitable barriers, signs and lights, at Contractor's expense, such that adequate protection is provided to the public against accident by reason of such open construction. Obstructions such as material piles and equipment shall be provided with similar warning lights and signs.
8. All streets, roads, highways and other public thoroughfares which are closed to traffic, under the authority of a proper permit shall be protected, at Contractor's expense, by means of effective barricades on which shall be placed proper warning signs; such barricades being located at the nearest intersecting public highway or street on each side of the blocked section of such public thoroughfare.
9. All barricades and obstructions shall be illuminated by means of amber lights at night and all lights used for this purpose shall be at Contractor's expense and shall be kept burning from sunset to sunrise. Materials stored upon or along side public streets and highways shall be so placed, and the work at all times shall be so conducted, as to cause the minimum obstruction and inconvenience to the traveling public. All barricades, signs, lights and other protective devices in public rights-of-way shall be installed and maintained in conformity with applicable statutory requirements and as required by the Manual on Uniform Traffic Control Devices, as amended, or any other applicable statutes or ordinances.

GC-21. SAFETY

1. Contractor shall be responsible for enforcing safety rules to assure protection of the employees and property of City, to assure uninterrupted production and to assure safe working conditions for Contractor and Subcontractors and their employees and to assure the safety of the general public. In addition to any other rights the City might exercise, Contractor and/or any Subcontractor failing to follow safety rules shall be subject to eviction from the job site and may be refused reentry.

Contractor shall designate a responsible member of its organization on the Project whose duty shall be the prevention of accidents. The name and position of the person so designated shall be reported to the City Public Works Director by

Contractor. In the absence of such designation, the Contractor's Superintendent shall be deemed to be the safety representative.

2. Contractor shall develop and maintain an up-to-date emergency action plan, taking into account fires, hazardous materials, explosions, adverse weather, floods, etc, which shall be in compliance with all federal, state and local laws and ordinances. The procedures should outline specific action to be taken to protect life and to secure and protect the building materials, constructed work, buildings, equipment and the position of cranes, and shall cover, at a minimum, personal safety training for employees and subcontractors equipment; first aid-personnel and facilities; fire protection; signs, signals, and barricades; safety inspections; material handling and storage; inspections; and corrective action.
3. In an emergency affecting the safety of life, the Work, the City's property or of adjoining property, Contractor, without special instruction or authorization from the City Public Works Director, is hereby permitted to act, at its discretion, to prevent such threatened injury or loss. Any compensation claimed by Contractor on account of emergency work shall be determined by mutual agreement of City and Contractor.
4. Whenever, in the opinion of the City Public Works Director, the Contractor has not taken sufficient precaution for the safety of the public or the protection of the Work to be constructed under this Contract, or of adjacent structures or property which may be injured by process of construction, and whenever, in the opinion of the City Public Works Director, an emergency shall arise and immediate action shall be considered necessary in order to protect property interests and to avoid personal injury and/or death, then the City Public Works Director, with or without notice to the Contractor, shall have the authority to cause such work to be done and materials to be furnished at places as the City Public Works Director may consider necessary and adequate. The cost and expense of such work and material so furnished shall be borne by the Contractor. The performance of such emergency work shall in no way relieve the Contractor of responsibility for damages which may occur during or after such precaution has been duly taken.

GC-22 REPORTING OF INJURY OR DAMAGE.

1. The Contractor shall be responsible for an damage to the Work, whether due to accident, adverse weather, malicious mischief, riot, sabotage, theft, etc., and shall promptly return the Work to its previous condition at no cost to the City. If the loss is covered by property insurance, Contractor shall immediately report the damage and cooperate with the insurer on claims for reimbursement, but Contractor shall nevertheless promptly repair the damage so that the Work can proceed. The Contractor shall promptly remedy damage and loss (other than damage or loss insured under property insurance required by the Contract Documents) to property caused in whole or in part by the Contractor, a

Subcontractor, a Sub-subcontractor, or anyone directly or indirectly employed by any of them, or by anyone for whose acts they may be liable, except damage or loss attributable to acts or omissions of the City or anyone directly or indirectly employed by City, or by anyone for whose acts the City may be liable, and not attributable to the fault or negligence of the Contractor. The foregoing obligations of the Contractor are in addition to the Contractor's obligations under the Indemnification provision of this Contract.

2. If either party suffers injury or damage to person or property because of an act or omission of the other party, or of others for whose acts such party is legally responsible, written notice of such injury or damage, whether or not insured, shall be given to the other party within a reasonable time not exceeding 21 days after discovery. The notice shall provide sufficient detail to enable the other party to investigate the matter.

GC-23. HAZARDOUS MATERIALS

1. When use or storage of explosives or other hazardous materials or equipment or unusual methods are necessary for execution of the Work, the Contractor shall exercise utmost care and carry on such activities under supervision of properly qualified personnel.
2. The Contractor is responsible for compliance with any requirements included in the Contract Documents regarding hazardous materials. If the Contractor encounters a hazardous material or substance not addressed in the Contract Documents and if reasonable precautions will be inadequate to prevent foreseeable bodily injury or death to persons resulting from a material or substance, including but not limited to asbestos or polychlorinated biphenyl (PCB), encountered on the Site by the Contractor, the Contractor shall, upon recognizing the condition, immediately stop Work in the affected area and report the condition to the City Public Works Director in writing.
3. Upon receipt of the Contractor's written notice, the City shall take reasonable steps to verify the presence or absence of the material or substance reported by the Contractor and, in the event such material or substance is found to be present, to cause it to be rendered harmless. When the material or substance has been rendered harmless, Work in the affected area shall resume upon written agreement of the City and Contractor. By Change Order, the Contract Time shall be extended appropriately and the Contract Sum shall be increased in the amount of the Contractor's reasonable additional costs of shut-down, delay and start-up.
4. To the fullest extent permitted by law, the City shall indemnify and hold harmless the Contractor, Subcontractors, their agents and employees of any of them from and against claims, damages, losses and expenses, including but not limited to

attorneys' fees, arising out of or resulting from performance of the Work in the affected area if in fact the material or substance presents the risk of bodily injury or death and has not been rendered harmless, provided that such claim, damage, loss or expense is attributable to bodily injury, sickness, disease or death, or to injury to or destruction of tangible property (other than the Work itself), except to the extent that such damage, loss or expense is due to the fault or negligence of the party seeking indemnity. The City shall not be responsible under this Section for materials or substances the Contractor brings to the Site unless such materials or substances are required by the Contract Documents. The City shall be responsible for materials or substances required by the Contract Documents, except to the extent of the Contractor's fault or negligence in the use and handling of such materials or substances. The City shall also indemnify the Contractor against fines, penalties or other costs assessed by government agencies for the cost of remediation of a hazardous material or substance solely by reason of performing Work as required by the Contract Documents.

5. The Contractor shall indemnify the City for the cost and expense the Owner incurs (1) for remediation of a material or substance the Contractor brings to the Site and negligently handles, or (2) where the Contractor fails to perform its obligations under this Section, except to the extent that the cost and expense are due to the City's fault or negligence.

GC-24. CUTTING, PATCHING AND DIGGING

1. Contractor shall do all cutting, fitting or patching of its work so that may be required to make its several parts come together properly and fit it to receive or be received by work of others shown upon or reasonably implied by the Contract Documents.
2. Contractor shall not endanger any property of City or any other individual or entity, or the Work by cutting, digging or otherwise and shall not cut or alter the work others except with the written consent of City.
3. Contractor shall assume responsibility for the patching or repairs, by the proper trade, of damages caused by work under this Contract.
4. Contractor shall comply with all local ordinances dealing with cutting, patching and digging and shall obtain all necessary permits.

GC-25. CLEANING UP

Contractor shall at all times keep the premises/site free from accumulations of waste material or rubbish caused by its employee or Work; and at the completion of the

daily Work it shall remove all its rubbish from and about the premises/site and all its tools, scaffolding and surplus materials, and shall leave its work "broom clean" or its equivalent unless more exactly specified. In case of dispute, City may remove the rubbish and charge the cost to Contractor.

GC-26. JOBSITE OFFICE AND TEMPORARY FACILITIES

1. If required by the Contract Documents, during the performance of this Contract, the Contractor shall maintain a suitable office at or near the site of the Work which shall be the headquarters of the superintendent authorized to receive drawings, instructions, or other communications or articles from the City Public Works Director, and any such communication given to the said superintendent or delivered at the Contractor's office at the site of the Work in his/her absence shall be deemed to have been given to the Contractor. Contractor shall coordinate the placement of such office with the City Public Works Director, but unless otherwise provided in the Contract, the City does not make any representation as to the availability of space, utilities, parking or other amenities for such office. Upon completion of Work or when requested by City Public Works Director, Contractor shall remove same from City's premises and leave the area in a clean and orderly condition.
2. The operations of the Contractor shall be in full conformity with all of the rules and regulations of boards and bodies having jurisdiction with respect to sanitation. The Contractor shall obey and enforce all sanitary regulations and orders, and shall take precautions against infectious diseases and the spread of same.
3. The Contractor shall supply safe and sufficient drinking water to all of its employees. All water used in the course of the Work shall be hauled in or purchased from the local Water Company's distribution system at the Contractor's own cost and expense.
4. Except where special permission has been granted by City, Contractor shall provide and maintain sanitary temporary toilet facilities located where directed by City Public Works Director for accommodation of all persons engaged on the Work. Temporary toilets shall be enclosed and weatherproof and kept in sanitary and an approved condition at all times. After use for same has ceased, Contractor shall remove the temporary toilet facilities from City's premises and disinfect and fill any vaults.
5. Contractor shall provide and maintain temporary heat as required to protect all Work and material against injury from dampness and/or cold to the satisfaction of City Public Works Director.

6. Unless otherwise specified in the Contract Documents, Contractor shall provide, at its cost and expense, temporary power, wiring and lights from City's provided source as may be required for its operations.

GC-27. SEPARATE CONTRACTS

1. City reserves the right to perform with its own forces or let other contracts in connection with the Project. Contractor shall afford reasonable opportunity for the introduction and storage of materials and the execution of work by City or others and shall properly connect and coordinate its Work with the work of City or others.
2. If any part of Contractor's Work depends upon the work of the City or others, Contractor shall inspect and promptly report to City any defects in any such work that renders it unsuitable for proper execution or results. Its failure to so inspect and report shall constitute an acceptance by it of such other work as fit and proper for the reception of its work.
3. In the event that Contractor is performing work at a site or on a project involving City and one or more other private or governmental entities, which have their own contractors on site as well, Contractor shall advise City Public Works Director when it anticipates that there may be interference with the Contractor's work or with the work of any other contractor. City Public Works Director shall, to the best of its ability, with input from Contractor as to coordination of the work, seek to schedule work of the various contractors so as to avoid as much inconvenience and delay as possible, and the Contractor agrees to cooperate with all other contractors, and it shall so conduct its operations so as to interfere to the least possible extent with the work of such contractors or workers; provided, however, that in the event Contractor experiences a delay or damage to the Contractor's work as a result of the presence of other such contractors the City may, in its discretion, grant an extension of Contract Time and/or an adjustment in the Contract Price as may be appropriate in the circumstances.
4. The Contractor shall be responsible for any injury or damages that may be sustained by other contractors, workers or their work because of any fault or negligence on Contractor's part, and shall at its own expense repair or pay for such injury or damage. Any difference or conflict which may arise between the Contractor and contractors or between the Contractor and the workers of the City or any other entity in regard to their work, shall be adjusted and determined by the City Public Works Director. If the Work of the Contractor is delayed or damaged because of any acts or missions of any other contractor or contractors, the City may, in its discretion, grant an extension of Contract Time and/or an adjustment in the Contract Price as may be appropriate in the circumstances.

5. When two or more contracts are being executed at one time in such manner that work on one contract may interfere with that on another, the City Public Works Director shall decide which contractor shall cease work and which shall continue, whether the work on both contracts shall progress at the same time, and in what manner the work is to proceed. Similarly, when the work site of one contract is the necessary or convenient means of access for the transportation or movement of workers, materials or appliances required for the execution of another contract, such privileges of access or any other responsible privilege may be granted by City Public Works Director to the contractor so desiring to the extent which may be reasonably necessary.

GC- 28 INSURANCE

The Contractor shall furnish insurance as described in **Exhibit K** to the Contract. Contractor's failure to submit Certificates of Insurance, and Additional Insured and Notice of Cancellation/Modification Endorsements to the City as provided in the Instructions to Bidders, and in all cases prior to commencement of any Work on site, shall be grounds for termination of this Contract and exercise of the City's remedies including, but not limited to, against Contractor's Bid security.

GC-29. SURETY BONDS/SECURITY FOR PAYMENT OF OBLIGATIONS

1. If required by the Contract Documents, Contractor shall, after Notice of Award, but as a precondition to enforcement of any right of Contractor with respect to the Contract, furnish City with a Performance Bond and a Payment Bond in the full amount of the Contract Price on the forms attached to the Contract as **Exhibits B-1 and B-2**. The Bonds shall be provided by a Treasury-listed, corporate surety admitted in the State of Missouri, with an A. M. Best Rating of A- or better, and accompanied by valid Powers of Attorney if executed by an agent of the surety. Failure to furnish such Bonds within the time specified in the Notice of Award may, at the City's option, be the basis for declaring Contractor in default and pursuing such legal rights as the City deems in its best interest, including, but not limited to, enforcement of the City's rights as to bid security.
2. Contractor shall be responsible for notifying its surety of any modifications to the Contract Price or Time, and said surety shall not seek discharge as a result of any failure on Contractor's part to notify surety. If Changes to the Contract result in an increase in the Contract Price, the Contractor will be reimbursed for any additional surety bond premium, and the Contractor shall obtain a Rider to the surety bonds increasing their penal sum accordingly.
3. If the City does not require the submission of Performance and Payment Bonds, it may require Contractor to submit additional documentation to verify that the Contractor has satisfied all of its financial obligations with respect to the Contract.

GC-30. DELAYS AND EXTENSION OF TIME

1. If Contractor shall be delayed at any time in the progress of the Work by an act or omission of City, or direction of the City Public Works Director to delay or suspend Work, or by any separate contractor employed by City and over which Contractor has no control and which is not a result of the Contractor's acts or the acts of any of its employees, Subcontractors or suppliers, negligent or otherwise, then the Contract Time and the Contract Price may be extended and/or adjusted for such reasonable time and amount as the City Public Works Director shall decide, provided, that the Contractor would not have been delayed by a cause not attributable to the City or a separate contractor.
2. If adverse weather conditions are the basis for a request for additional time, such request shall be documented by data substantiating that weather conditions were abnormal for the period of time, could not have been reasonably anticipated, and had an adverse effect on the scheduled construction.
3. If the parties are unable to agree upon an appropriate Extension of Time, the Contractor shall assert a Claim in accordance with applicable provisions of this Contract's Disputes section.
4. If the Contractor is not entitled to an Extension of Time, the Owner shall be entitled to recover its actual costs, or liquidated damages as stated in the Contract, attributable to the delay by the Contractor.
5. No request for an extension of time shall be made for delay unless Contractor provides written notice to City Public Works Director of such delay, the reasons therefor and the expected length of delay within two business days of the commencement of such delay, in order to afford the City the maximum opportunity to take such action as it deems appropriate to minimize the delay or the consequences thereof. In the case of continuing cause of delay, only one written notice is necessary.
6. If the Contract Documents include a requirement that the Contractor provide maintenance services on the Work, the Contractor shall be required to deliver a Maintenance Bond on the form attached at **Exhibit B-3** prior to release of Final Payment

GC-31. CHANGES IN THE WORK

1. Change Orders. The City, without invalidating the Contract, may by direct changes in the Work which may result in an addition to or deduction from the Contract Price and/or changes in the Contract Time. A change which is agreed upon by the City and the Contractor shall be commemorated in a Change Order to be prepared by the City Public Works Director, and signed by the City and the

Contractor. Change orders of \$1,000 or less may be authorized and executed by the City Public Works Director on behalf of the City. Change Orders of \$2,500 or less may be authorized and executed by the City Administrator on behalf of the City. Change Orders of more than \$2,500 require the authorization and signature of the Mayor following approval by the City's Finance Committee and/or Board of Aldermen. The Contractor shall then be entitled to bill and be paid for the Work of the Change in the same manner as all other payments under the Contract. The Work as changed shall be subject to all the same terms and conditions as original work under this Contract.

2. Quantity Variations. Where changes in the Work involve a change in the quantity of any item paid based on unit prices, the Contract Price shall be revised by extension of the quantities and unit price such items so changed subject to written approval of the City Public Works Director. If the quantity is increased or decreased by thirty-three percent (33%) or more, and the total value of the Work affected is at least twenty percent (20%) of the Contract Price, either party may request that the City Public Works Director equitably adjust the unit price. The City Public Works Director shall advise both parties in writing of his decision on such adjustment within ten days of receipt of substantiating information from the requesting party, subject to both parties' right to dispute this decision. Pending resolution of such dispute, however, the Contractor shall be entitled to bill and be paid for the Work at the unit prices determined by the City Public Works Director in the same manner as all other payments under the Contract.
3. Minor Changes. City Public Works Director may order minor changes in the Work through field orders, which in no material or substantial way increase or decrease the Work; and such minor changes in the Work shall not involve an addition or deduction from the Contract Price nor an extension of the Contract Time.
4. Work Directives. From time to time the City Public Works Director may also issue written orders to Contractor for needed clarifications, modifications or corrections. If the Contractor and the City do not agree that such written order is a change, or on what if any adjustment to the Contract Price or Contract Time is appropriate, the City Public Works Director shall issue a directive to the Contractor describing the Work affected thereby, and the Contractor shall immediately comply with it subject to the other terms of the Contract. Any appropriate adjustment to the Contract price or Contract Time shall be resolved as follows.

The City Public Works Director shall either:

- (a) make a good faith evaluation of the appropriate adjustment to the Contract Price and/or Contract Time within ten days of receipt of substantiating proposal from the Contractor, and the Contractor shall be permitted to bill for the changed work as otherwise provided in the Contract Documents; or

- (b) direct the Contractor to keep an accurate account of its Allowable Field Costs as provided for below, and the Contractor shall be permitted to bill for, and receive, such costs plus fifteen percent (15%) as its full compensation for the Contractor's profit, overhead, general superintendence, field office expense and all other elements of cost not embraced within the Allowable Field Costs; or
- (c) If the City Public Works Director has determined in good faith that no change has occurred, and that the work covered by the Work Directive is part of the Contractor's obligations under the Contract Documents, the City Public Works Director directs the Contractor to proceed with the Work. The Contractor may keep records of its allowable costs and submit them through the disputes process as otherwise provided herein.
- (d) Where a Work Directive results in a credit to the City, the credit will be for allowable costs only, and no credit will be given back to the City for overhead or profit unless the Work reduced equals or exceeds ten percent (10%) of the Contract Price.
- (e) If the City Public Works Director determines that the value of any work performed under a Work Directive shall be based on costs incurred, the Contractor shall keep accurate records of its Allowable Field Costs as defined below.
 - (i) Where extra work is to be compensated based on Allowable Field Costs, only the following costs, as actually incurred and documented, will be paid to the Contractor:
 - (1) The cost of all workers, such as foremen, timekeepers, mechanics, and laborers, for the time actually employed in the performance of the said extra work;
 - (2) All materials and supplies;
 - (3) Trucks and rental on machinery and equipment for the time actually employed or used in the performance of said extra work, but not to exceed the purchase price of any such items if rented from third parties, and, if the items are owned by Contractor or an affiliate of Contractor, the rental rate shall not exceed eight-five percent (85%) of the local standard rental rate for similar items;
 - (4) Any transportation or travel charges necessarily incurred in connection with said equipment authorized by the City Public Works Director for use on said work and similar operating expenses;

- (5) All incidental expenses incurred as a direct result of such extra work, including payroll taxes and a ratable proportion of premiums for insurance, where the premiums therefor are based on payroll costs, public liability and property damage, worker's compensation, and other insurance required by the Contract; provided, however, Contractor must enumerate and justify to City's satisfaction any such claimed incidental expenses;
 - (6) Additional premiums for surety bonds, upon receipt by the City of riders increasing the penal sum of the bonds.
- (ii) Without in any way limiting City's right to challenge any individual costs claimed by Contractor, incidental costs shall not include:
- (1) Payroll costs and other compensation of Contractor's officers, executives, principals (of partnership and sole proprietorships), general managers, Public Works Directors, architects, estimators, lawyers, auditors, accountants, purchasing and contracting agents, expeditors, timekeepers, clerks and other personnel employed by Contractor whether at the site or in Contractor's principal or a branch office for general administration of the work unless specifically agreed to by City - all of which are to be considered administrative costs covered by the Contractor's overhead and profit.
 - (2) Expenses of Contractor's principal and branch offices other than Contractor's office at this site.
 - (3) Any part of Contractor's capital expenses, including interest on Contractor's capital employed for the Work and charges against Contractor for delinquent payments.
 - (4) Costs due to the negligence of Contractor, any Subcontractor, or anyone directly or indirectly employed by any of them or for whose acts any of them may be liable, including but not limited to, the correction of defective Work, disposal of materials or equipment wrongly supplied and making good any damage to property.
 - (5) Other overhead of general expense costs of any kind and the costs of any item not specifically and expressly agreed to by City.

The City Public Works Director may direct the form in which accounts of the Allowable Field Cost shall be kept and may also specify in writing, before the Work commences, the method of doing the Work and the type and kind of machinery and equipment, if required, which shall be used in the performance of extra work

5. If either party wishes to take exception to the City Public Works Director's decisions as to whether an item constitutes a Change, or the appropriate adjustment to the Contract Price or Contract Time associated with a Change, it shall notify the City Public Works Director, with a copy of such notice to the other party, within seven (7) days of receipt of the City Public Works Director's decision. Failure to give such notice shall constitute acceptance of the City Public Works Director's decision.
6. Except for Work done as a result of an emergency endangering life or property, no Work resulting in an additional pay item shall be performed unless pursuant to the provision of a Change Order or a Work Directive.

GC-32. INDEMNITY

1. Definitions. For purposes of indemnification requirements as set forth throughout the Contract, the following terms shall have the meanings set forth below:
 - (a) "The Contractor" means and includes Contractor, all of his affiliates and subsidiaries, his Subcontractors and materialmen and their respective servants, agents and employees; and
 - (a) "Loss" means any and all loss, damage, liability or expense, of any nature whatsoever, whether incurred as a judgment, settlement, penalty, fine or otherwise (including attorney's fees and the cost of defense), in connection with any action, proceeding, demand or claim, whether real or spurious, for injury, including death, to any person or persons or damages to or loss of, or loss of the use of, property of any person, firm or corporation, including the parties hereto, which arise out of or are connected with, or are claimed to arise out of or be connected with, the performance of this Contract whether arising before or after the completion of the Work required hereunder.
2. The Indemnities. For purposes of this Contract, and without in any way limiting indemnification obligations that may be set forth elsewhere in the Contract, and to the greatest extent permitted by applicable law, Contractor hereby agrees to indemnify, defend and hold harmless the City from any and all Loss to the extent such Loss is caused or incurred by, on account of or as a result of the negligence or other actionable fault of the Contractor, its employees, agents, Subcontractors and suppliers or any other party for whom Contractor is responsible.

It is agreed as a specific element of consideration of this Contract that this indemnity shall apply notwithstanding the joint, concurrent or contributory or comparative fault or negligence of the City or any third party and, further, notwithstanding any theory of law including, but not limited to, a characterization of the City's or any third party's joint, concurrent or contributory or comparative fault or negligence as either passive or active in nature.

Additionally, Contractor agrees to defend any claim, action or suit that may be brought against City, its governing body, officers, agents or employees for infringement of any patents arising out of the performance of this Contract or out of the use or disposal by or for the account of City of supplies furnished or construction work performed hereunder, and also to indemnify and hold harmless City, its governing body, officers, agents, and employees against all judgments, decrees, damages, costs and expenses recovered against it or them sustained by it or them on account of any such actual or alleged infringement.

3. General Limitation. Nothing in this section shall be deemed to impose liability on the Contractor to indemnify the City for Loss to the extent that the City's negligence or other actionable fault is the cause of Loss.
4. Waiver of Statutory Defenses. With respect to the City's rights as set forth herein and to the greatest extent permitted by applicable law, the Contractor expressly waives all statutory defenses, including, but not limited to, those under workers compensation, contribution, comparative fault or similar statutes to the extent said defenses are inconsistent with or would defeat the purposes of this section.

GC-33. ASSIGNMENT OF CONTRACT

Contractor shall not assign any of its rights under the Contract without the express, advance written consent of the City. In case the Contractor assigns all, or any part, of the monies due or to become due under this Contract, the right of the assignee in and to any monies due or to become due the Contractor shall be subject to all prior claims of all persons, firms, and corporations for services rendered or materials supplied for the performance of the Work called for in this Contract and no money shall be paid assignee on behalf of the Contractor by the City until such time as the Contractor has discharged its obligations to the City under the Contract. It is expressly understood and agreed that no assignment shall be effective as against the City unless it complies with the foregoing.

GC-34. SUBCONTRACTING

1. The Contractor shall not make any substitution for any Subcontractor unless the City so agrees in writing. The City reserves the right to disapprove the use of any subcontractor, but its failure to exercise such right shall not constitute acceptance of the work of any subcontractor. Disapproval of a subcontractor shall not be grounds for an adjustment to the Contract Price or Contract Time.
2. Should any Subcontractor fail to perform in a satisfactory manner, the Contractor shall immediately take appropriate action to rectify the failure of its Subcontractors. The Contractor shall be as fully responsible to the City for the

acts and omissions of its Subcontractors, and of persons either directly or indirectly employed by them, as Contractor is for the acts and omissions of persons directly employed by it.

3. The Contractor shall cause appropriate provisions to be inserted in all subcontracts to bind Subcontractors to the Contractor by the terms of the Contract Documents insofar as applicable to the work of the Subcontractor and to give the Contractor the same power to terminate any subcontract as the City has to terminate the Contractor under any provisions of the Contract Documents.
4. Contingent Assignment of Subcontracts to City. Each subcontract agreement for a portion of the Work is assigned by the Contractor to the City, provided that
 - (a) assignment is effective only after termination of the Contract by the City for cause pursuant to this Contract's termination provisions, and only for those subcontract agreements that the Owner accepts by notifying the Subcontractor and Contractor in writing; and
 - (b) assignment is subject to the prior rights of the surety, if any, obligated under bond relating to the Contract.
 - (c) When the City accepts the assignment of a subcontract agreement, the Owner assumes the Contractor's rights and obligations under the subcontract.
 - (d) Upon such assignment, if the Work has been suspended for more than 30 days, and if a Subcontractor provides backup for additional costs arising from the suspension, the Subcontractor's compensation shall be equitably adjusted for increases in cost resulting from the suspension.
 - (e) Upon such assignment to the City under this Section, the City may further assign the subcontract to a successor contractor or other entity. If the City assigns the subcontract to a successor contractor or other entity, the City shall nevertheless remain legally responsible for all of the successor contractor's obligations under the subcontract.
6. Nothing contained in the Contract Documents shall create any contractual relationship between any Subcontractor and the City, nor shall anything contained in the Contract Documents create any obligation on the part of the City to pay to or to see to the payment of any sums due any Subcontractor.

GC-35. CORRECTION OF WORK

1. The Contractor shall promptly correct Work rejected by the City Public Works Director or Inspector or failing to conform to the requirements of the Contract Documents, whether discovered before or after Substantial Completion and

whether or not fabricated, installed or completed, and remove from the site portions of the Work that are not in accordance with the requirements of the Contract Documents. Costs of correcting such rejected Work, including additional testing and inspections, the cost of uncovering and replacement of destroyed or damaged construction (whether completed or partially completed) of the City or separate contractors caused by the Contractor's correction or removal of Work, and compensation for the Inspector's services and expenses made necessary thereby, shall be at the Contractor's expense.

2. If Contractor should neglect to prosecute the work properly or fail to perform any provision of the Contract Documents, the City, after three (3) days' written notice to Contractor may, without prejudice to any other remedy it may have, make good such deficiencies and may deduct the cost thereof from the payment then or thereafter due Contractor.
3. In addition to the Contractor's Warranty obligations if, within two years after the date of Substantial Completion of the Work or designated portion thereof (or, if the Work in question was performed after Substantial Completion, from the date on which the Work was completed) or after the date for commencement of warranties or by terms of an applicable special warranty required by the Contract Documents, any of the Work is found to be not in accordance with the requirements of the Contract Documents, the Contractor shall correct it promptly after receipt of written notice from the City Public Works Director to do so, unless the City Public Works Director has previously given the Contractor a written acceptance of such condition. The Owner shall give such notice promptly after discovery of the condition. During the two-year period for correction of Work, if the City Public Works Director fails to notify the Contractor and give the Contractor an opportunity to make the correction, the City waives the rights to require correction by the Contractor and to make a claim for breach of warranty. If the Contractor fails to correct nonconforming Work within a reasonable time during that period after receipt of notice from the City Public Works Director, the City may correct it in accordance with the provisions of this Contract.
4. Nothing contained in this Section shall be construed to establish a period of limitation with respect to other obligations the Contractor has under the Contract Documents. Establishment of the two-year period for correction of Work as described herein relates only to the specific obligation of the Contractor to correct the Work, and has no relationship to the time within which the obligation to comply with the Contract Documents may be sought to be enforced, nor to the time within which proceedings may be commenced to establish the Contractor's liability with respect to the Contractor's obligations other than specifically to correct the Work.
5. If the City prefers to accept Work that is not in accordance with the requirements of the Contract Documents, the City may do so instead of requiring its removal and correction, in which case the Contract Price will be reduced as appropriate

and equitable. Such adjustment shall be effected whether or not final payment has been made.

GC-36. DISPUTE RESOLUTION

1. City and Contractor agree that disputes relative to the Work shall first be addressed by negotiations between the parties. Such negotiations shall take place within thirty (30) days of demand by the party seeking resolution of the dispute. If direct negotiations fail to resolve the dispute, the party initiating the claim that is the basis for the dispute shall be free to take such steps as it deems necessary to protect its interests; provided, however, that notwithstanding any such dispute Contractor shall proceed with the Work as per the Contract Documents as if no dispute existed.
2. In order to preserve its rights to dispute a matter hereunder, the complaining party must submit a written notice to the other party setting forth the basis for its complaint within twenty (20) calendar days following receipt of the decision of the City Public Works Director as to such matter or other action on which the dispute is based. A decision of the City Public Works Director (where appropriate) under GC-7 above; notice of dispute, and direct negotiation, shall be conditions precedent to any further legal action.
3. Should the Contractor believe that it is entitled to any relief due to errors, omissions or defects in the Plans or Specifications, or as a result of any act or omission of an independent contractor designer in connection with the Project, the City shall cooperate with the Contractor by permitting the Contractor to pursue legal action against the designer in the name of the City at Contractor's sole risk and expense as the City would otherwise have against such designer. The City shall pay to Contractor such sums as may be recovered from the designer on behalf of Contractor. Other than this duty of cooperation and remittance, the City shall have no liability or obligation to Contractor for any act, error, omission, negligence or breach of duty by a designer.
4. Arbitration of disputes.
 - a. Claims, except those waived as provided for elsewhere in this Contract, which have not been resolved by mediation, shall be decided by arbitration which, unless the parties mutually agree otherwise, in accordance with the Construction Industry Arbitration Rules of the American Arbitration Association currently in effect at the time of the arbitration. The demand for arbitration shall be filed in writing with the other party to the Contract and with the American Arbitration Association.
 - b. A demand for arbitration may be made no earlier than concurrently with the filing of a request for mediation, but in no event shall it be made after

the date when institution of legal or equitable proceedings based on such Claim would be barred by the applicable statute of limitations.

- c. An arbitration pursuant to this Section may be joined with an arbitration involving common issues of law or fact between the Owner or Contractor and any person or entity with whom the Owner or Contractor has a contractual obligation to arbitrate disputes which does not prohibit consolidation or joinder. No other arbitration arising out of or relating to the Contract shall include, by consolidation, joinder or in any other manner, an additional person or entity not a party to the Contract or not a party to an agreement with the Owner Contractor, except by written consent containing a specific reference to the Contract signed by the Owner and Contractor and any other person or entities sought to be joined. Consent to arbitration involving an additional person or entity shall not constitute consent to arbitration of any claim, dispute or other matter in question not described in the written consent or with a person or entity not named or described therein. The foregoing agreement to arbitrate and other agreements to arbitrate with an additional person or entity duly consented to by the parties to the Contract shall be specifically enforceable in accordance with applicable law in any court having jurisdiction thereof.
- d. Claims and Timely Assertion of Claims. The party filing a notice of demand for arbitration must assert in the demand all Claims then known to that party on which arbitration is permitted to be demanded.
- e. Judgment on Final Award. The award rendered by the arbitrator or arbitrators shall be final, and judgment may be entered upon it in accordance with applicable law in any court having jurisdiction thereof.

GC-37. RIGHT OF CITY TO SUSPEND OR TERMINATE CONTRACT

1. Suspension of Work by the City . The City Public Works Director may, without cause, order the Contractor in writing to suspend, delay or interrupt the Work in whole or in part for such period of time as the City may determine. The Contract Price and Contract Time shall be adjusted for increases in the cost and time caused by such suspension, delay or interruption. No adjustment shall be made to the extent that performance is, was or would have been so suspended, delayed or interrupted by another cause for which the Contractor is responsible; or that an equitable adjustment is made or denied under another provision of the Contract.
2. Termination of the Contract by the City. If any of the conditions enumerated below are found by the City to have occurred:
 - (a) the Work to be done under this Contract shall be abandoned by the Contractor; or

- (b) this Contract shall be assigned by Contractor otherwise than as herein provided; or
- (c). at any time the City Public Works Director shall certify in writing to the City that:
- (i) the performance of the Work under this Contract is being unnecessarily delayed such that all Bid items of the Project are not completed within the time named for their completion or within the time to which such completion date may be extended;
 - (ii) that the Contractor is violating any of the conditions or covenants of this Contract or the specifications therefor;
 - (iii) that the Contractor is executing the same in bad faith or otherwise not in accordance with the terms of said Contract; or
 - (iv) if the Contractor defaults in any material manner in its performance of the Contract; or
- (d) a petition should be filed in bankruptcy by the Contractor, or by others seeking to have Contractor adjudged bankrupt and a motion is not made by Contractor within ten (10) days seeking assumption of the Contract and manifesting the ability to fulfill all of Contractor's obligations and curing all of Contractor's defaults; or if a general assignment of its assets should be made for the benefit of its creditors; or if a receiver should be appointed for the Contractor or any of its property;

then, in addition to other rights the City may choose to exercise, the City may, at its option, serve written notice upon the Contractor and its surety of City's intention to terminate this Contract, and unless within five (5) days after the serving of such notice upon the Contractor, a satisfactory arrangement be made for the continuance thereof, this Contract shall cease and terminate.

3. In the event of such termination, the City shall immediately serve notice thereof upon the surety and the Contractor, and the surety shall have the right to take over and complete the Work; provided, however, that if the surety does not commence performance thereof promptly, the City may take over the Work and prosecute same to completion, by contract or otherwise, for the amount and at the expense of the Contractor, and the Contractor and its surety shall be liable to the City for any and all excess cost sustained by the City by reason of such prosecution and completion; and in such event the City may take possession of, and utilize in completing the Work, all such materials, equipment, tools and plant as may be on the site of the Work and necessary therefor.

4. When Contractor's services have been so terminated, such termination shall not affect any rights or remedies of City against Contractor then existing or which may later accrue. Similarly, any retention or payment of monies due Contractor shall not release Contractor from liability.
5. The City also reserves the right, in its sole discretion and for its convenience and without cause or default on the part of Contractor, to terminate the Contract by providing written notice of such termination to Contractor. Upon receipt of such notice from City, Contractor shall: (1) immediately cease all work; or (2) meet with City and, subject to City's approval, determine what Work shall be required of Contractor in order to bring the Project to a reasonable termination in accordance with the request of City. If City shall terminate for its convenience as herein provided, City shall: (1) compensate Contractor for all purchased materials and actual cost of work completed to date of termination; and (2) release and indemnify Contractor against any liability Contractor may have to any third parties as the result of any contracts, commitments, purchase orders or any other such liabilities Contractor may have incurred as a result of its obligations under the provisions of the Contract. Contractor agrees that it shall minimize such potential liabilities by, where practical, informing third parties of City's right to terminate and attempting to obtain from such third parties a waiver of any liability in the event of such termination.
6. Any termination of the Contract for alleged default by Contractor that is ultimately determined to be unjustified shall automatically be deemed a termination for convenience of the City.

GC-38. PROGRESS PAYMENTS [if applicable]

1. Before submission of its first application for payment, the Contractor shall submit to the City Public Works Director a schedule of values allocating the various portions of the Work, prepared in such form and supported by such data to substantiate its accuracy as the City Public Works Director may require. This schedule, unless objected to by the City Public Works Director, shall be used only as a basis for the Contractor's applications for payment, but does not constitute approval by the City Public Works Director of the method or performance by the Contractor.
2. Payment will be made to Contractor monthly from funds available within thirty (30) days of the City's receipt of a proper undisputed pay request from the Contractor on the basis of a duly certified estimate of the value of all labor and materials delivered on the site and accepted by the City Public Works Director during the preceding month, calculated in proportion to the Contract price, but to ensure the proper performance of the Contract, five percent (5%) of the amount of each estimate will be retained, although the City reserves the right to increase retainage to ten percent (10%) if it determines, in its sole opinion, that the higher

rate is required to ensure performance of the Contract. Such retainage will be paid thirty (30) days after Substantial Completion of all work covered by the Contract unless the City is otherwise allowed by law to continue to retain said funds.

3. Unit Prices. Where the Contract provides that all or part of the Work is to be Unit Price Work, the Contract Price shall initially be deemed to include for all Unit Price Work an amount equal to the sum of the established unit prices for each separately identified item of Unit Price Work multiplied by the estimated quantity of each item required for the Work. It is understood and agreed that estimated quantities of items for Unit Price Work are not guaranteed and are solely for the purpose of comparison of bids and determining an initial Contract Price. Determinations of actual quantities and classifications of Unit Price Work shall be made by the City Public Works Director. Each unit price shall be deemed to include Contractor's overhead and profit for each separately identified item.
4. Each payment made to the Contractor shall be on account of the total amount payable to the Contractor by or for the City, and all materials and Work covered by the partial payments made shall therefore become the sole property of the City. This provision shall not be construed as relieving the Contractor from the responsibility imposed by the Contract Documents for the care and protection of materials and Work upon which payments have been made, for the restoration of any damaged Work, or as a waiver of the right of the City to require the fulfillment of all the terms of the Contract. Progress payments in respect to materials will be made only for materials delivered on the site and accepted by the City Public Works Director, all calculated in proportion to the Contract Price.
5. In general, no payment will be made in estimates for materials delivered on the site and not incorporated in the Work unless approved by the City Public Works Director as being in the best interests of the City, and title to such materials is transferred to the City by Bill of Sale on the form attached to the Contract as **Exhibit L**. Payment shall not be permitted for materials not delivered to the site except as approved by the City Public Works Director as being in the best interests of the City, and the City has received both a fully executed Bill of Sale and a satisfactory Bailment Agreement on the form attached to the Contract as **Exhibit M**.
6. The retained percentages herein provided for are to be retained and held for the sole protection and benefit of the City, and no other person, firm or corporation shall have or assert any lien, claim, right or priority therein, thereon or thereto, or be entitled to receive any part thereof, except as herein expressly provided.
7. The City shall require the Contractor to submit with its payment applications completed and notarized Partial Release and Waiver of Claim form from itself, and all Subcontractors and vendors with contract values of \$1,000 or more on the form attached to the Contract at **Exhibit N**. Contractor's failure to furnish said

waivers shall not relieve Contractor or its surety of any obligation assumed under this Contract, nor shall the City's request for such documentation create any obligation on City's part to verify accuracy.

8. The Contractor has bid this job net of all sales and compensation taxes. No application for payment shall include any amount for reimbursement of such taxes paid by Contractor resulting from Contractor's failure to use City's tax exemption certificate for any purchase in connection with the Work.
9. The Contractor shall be responsible for the return and /or exchange of surplus materials, and all credits for returned or exchanged materials shall be first submitted to the City Public Works Director for approval. Applications for payment shall reflect any such credits, and the Contract Price shall be adjusted as necessary to reflect such credits. Unreturnable excess materials shall be turned over to the City, or, at its option, be removed from the Project site at Contractor's expense.

GC-39 INSPECTION FOR SUBSTANTIAL COMPLETION AND RELEASE OF FUNDS

1. When the Contractor considers that the Work, or a portion thereof which the City agrees to accept separately, is substantially complete, the Contractor shall prepare and submit to the City Public Works Director a comprehensive list of items to be completed or corrected prior to final payment (the "Punch List"). Failure to include an item on the Punch List does not alter the responsibility of the Contractor to complete all Work in accordance with the Contract Documents.
2. Upon receipt of the Punch List, the City Public Works Director and/or the Inspector will make an inspection to determine whether the Work or designated portion thereof is substantially complete. If the inspection discloses any item, whether or not included on the Punch List, which is not sufficiently complete in accordance with the Contract Documents so that the City can occupy or utilize the Work or designated portion thereof for its intended use, the Contractor shall, before issuance of the Certificate of Substantial Completion, complete or correct such item upon notification by the City Public Works Director. In such case, the Contractor shall then submit a request for another inspection to determine Substantial Completion.
3. When the Work or designated portion thereof is substantially complete, the City Public Works Director will prepare and submit to the City and the Contractor a Certificate of Substantial Completion that shall establish the date of Substantial Completion, shall establish responsibilities of the City and Contractor for security, maintenance, heat, utilities, damage to the Work and insurance, and shall fix the time within which the Contractor shall finish all items on the list accompanying the Certificate. The City Public Works Director shall agree upon a reasonable value of Work not yet completed, and identify these in writing. Warranties required by the Contract Documents shall commence on the date of Substantial

Completion of the Work or designated portion thereof unless otherwise provided in the Certificate of Substantial Completion.

4. The City shall make payment of retainage applying to such Work or designated portion thereof, less 150% of the value of the remaining Work to be completed, and funds sufficient to protect the City from threatened claims, losses or other identified financial obligations of Contractor.

GC-40. PARTIAL OCCUPANCY OR USE

1. The City may occupy or use any completed or partially completed portion of the Work at any stage when such portion is designated by separate agreement with the Contractor, provided such occupancy or use is consented to by the insurer and authorized by public authorities having jurisdiction over the Project. Such partial occupancy or use may commence whether or not the portion is substantially complete, provided the City and Contractor have accepted in writing the responsibilities assigned to each of them for payments, retainage, liquidated damages (if any), security, maintenance, heat, utilities, damage to the Work and insurance, and have agreed in writing concerning the period for correction of the Work and commencement of warranties required by the Contract Documents. When the Contractor considers a portion substantially complete, the Contractor shall prepare and submit a list to the City Public Works Director as provided above. Consent of the Contractor to partial occupancy or use shall not be unreasonably withheld.
2. Immediately prior to such partial occupancy or use, the City Public Works Director and Contractor shall jointly inspect the area to be occupied or portion of the Work to be used in order to determine and record the condition of the Work.
3. In the event the City chooses to accept partial utilization of the Work, the amount of liquidated damages shall be equitable adjusted to reflect the relative value and potential damages associated with late completion of the remaining Work.
4. Unless otherwise agreed upon, partial occupancy or use of a portion or portions of the Work shall not constitute acceptance of Work not complying with the requirements of the Contract Documents.

GC-41. FINAL COMPLETION AND FINAL PAYMENT

1. Upon receipt of the Contractor's written notice that the Work is ready for final inspection and acceptance and upon receipt of a final Application for Payment, the City Public Works Director and/or Inspector will promptly make such inspection to determine if the Work is acceptable under the Contract Documents and the Contract fully performed. Before final acceptance, all installed and constructed equipment, devices and other Work which is to be tested under the

Contract Documents shall be tested and each part shall be in good condition and working order or shall be placed in such condition and order at the expense of the Contractor. All tests of such completed Work required under this Contract shall be made under the direction of the City Public Works Director. Upon agreement that the Work is complete, final payment of all remaining sums due to Contractor shall be made within fifteen days of compliance by Contractor with all requirements.

2. Neither final payment nor any remaining retained percentage shall become due until the Contractor submits to the City Public Works Director:
 - (a) an affidavit that payrolls, bills for materials and equipment, and other indebtedness connected with the Work (less amounts withheld by the City) have been paid or otherwise satisfied,
 - (b) a certificate evidencing that insurance required by the Contract Documents to remain in force after final payment is currently in effect and will not be canceled or allowed to expire until at least 30 days' prior written notice has been given to the City,
 - (c) a written statement that the Contractor knows of no substantial reason that the insurance will not be renewable to cover the period required by the Contract Documents,
 - (d) consent of surety to final payment,
 - (e) final Waivers and Release of Claims from Contractor and all Subcontractors and Vendors with a contract value of \$1,000 or more on the form attached hereto as **Exhibit O**,
 - (f) a current copy of the site plan on which Contractor shall show by dimensioning all underground utilities, above ground utilities, sewer clean-outs, yard hydrants, water meter, gas meter, electric meter and phone lines, and, if required by the City, other data establishing payment or satisfaction of obligations, to the extent and in such form as may be designated by the City, and
 - (g) receipt by the City of two copies of required sales tax exemption documentation on the forms attached to the Contract as **Exhibit F** from the Contractor.
3. If, after Substantial Completion of the Work, final completion thereof is materially delayed through no fault of the Contractor or by issuance of Change Orders affecting final completion, the City shall, upon application by the Contractor, and without terminating the Contract, make payment of the balance due for that portion of the Work fully completed and accepted. If the remaining balance for

Work not fully completed or corrected is less than retainage stipulated in the Contract Documents, and if bonds have been furnished, the written consent of surety to payment of the balance due for that portion of the Work fully completed and accepted shall be submitted by the Contractor to the City Public Works Director prior to certification of such payment. Such payment shall be made under terms and conditions governing final payment, except that it shall not constitute a waiver of claims.

4. The making of final payment shall constitute a waiver of Claims by the City except those arising from:
 - (a) liens, Claims, security interests or encumbrances arising out of the Contract and unsettled;
 - (b) failure of the Work to comply with the requirements of the Contract Documents; or
 - (c) terms of special warranties required by the Contract Documents.
5. Acceptance of final payment by the Contractor, a Subcontractor or material supplier shall constitute a waiver and release of claims by that payee except those previously made in writing and identified by that payee as unsettled at the time of final Application for Payment. Any payment, however, final or otherwise, shall not release the Contractor or its sureties from any obligations under the Contract Documents, the Bonds or insurance coverage.

GC-42. PAYMENTS WITHHELD

1. The City may withhold payment in whole or in part, to the extent reasonably necessary to protect the City, for any of the following reasons:
 - (a) defective Work not remedied;
 - (b) third party claims filed or reasonable evidence indicating probable filing of such claims unless security acceptable to the City is provided by the Contractor;
 - (c) failure of the Contractor to make payments properly to Subcontractors or for labor, materials or equipment;
 - (d) reasonable evidence that the Work cannot be completed for the unpaid balance of the Contract Price;
 - (e) damage to the City or a separate contractor;

- (f) reasonable evidence that the Work will not be completed within the Contract Time, and that the unpaid balance would not be adequate to cover actual or liquidated damages for the anticipated delay; or
- (g) repeated failure to carry out the Work in accordance with the Contract Documents.

The City may also nullify a payment previously issued, and withhold sums appropriate to protect the City from loss for which the Contractor is responsible. When the reasons for withholding payment are removed, payment will be made for amounts previously withheld.

- 2. The City may, at its sole option, issue joint checks to the Contractor and to any Subcontractor or material or equipment suppliers to whom the Contractor failed to make payment for Work properly performed or material or equipment suitably delivered.

GC-43. RETENTION OF RECORDS – CITY'S RIGHT TO AUDIT

Contractor shall maintain copies of records, including invoices reflecting sale or use tax information, pertaining to the Construction of this project for a period of five (5) years from the date of final payment. Such records shall be made available to the City for audit and review purposes upon written request therefor from City or its authorized agent(s) during the construction period and the five (5) year period following final payment.

GC-44. NOTICE

- 1. Written notice shall be deemed to have been duly served if delivered in person to the individual, to a member of the firm or entity, or to an officer of the corporation for which it was intended; or if delivered at, or sent by registered or certified mail or by courier service providing proof of delivery to, the last business address known to the party giving notice.
- 2. All notices of claims, potential changes or impediments to Contractor's ability to comply with the requirements of this Contract shall be given promptly and in writing, to allow the City the maximum opportunity to address and respond to them and to avoid impact to the Work.

GC-45. NO WAIVER OF RIGHTS

No waiver of any breach of this Contract shall be construed to be a waiver of any other subsequent breach.

GC-46. INDEPENDENT CONTRACTOR

The right of general supervision of the City and/or the City Public Works Director shall not make the Contractor an agent of the City, and the liability of the Contractor for all damages to persons, firms and corporations arising from the Contractor's execution of the Work shall not be lessened because of such general supervision, but as to all such person, firms and corporations, and the damages, if any, to them or their property, the contractor herein is an independent contractor in respect to the Work.

GC-47. SEVERABILITY

The parties agree that should any provision of the Contract Documents be determined to be void, invalid, unenforceable or illegal for whatever reason such provision(s) shall be null and void but that the remaining provisions of the Contract Documents shall be unaffected thereby and shall continue to be valid and enforceable.

GC-49. INTEREST

Payments due and unpaid under the Contract Documents shall bear interest from the date payment is due as required by Missouri law.

GC-49. GOVERNING LAW

This Contract shall be governed by, and construed in accordance with, the laws of the state of Missouri.

GC-50. VENUE

Venue of any litigation arising in connection with this Contract shall be the state courts of Platte County, Missouri.

EXHIBIT A-1

Special conditions

SC-1. WORK IN OR ACROSS STREET OR HIGHWAY RIGHT-OF-WAY

All work performed and all preparations of the Contractor or his employees, and Subcontractors, if any, within the limits of street or highway rights-of-way shall be in conformity with the requirements, and be under the control, through the City, of the street or highway authority owning or having jurisdiction and control over such rights-of-way in each case. Any costs incurred to comply with such requirements are the responsibility of the Contractor.

SC-2. CONTRACTOR TO FURNISH STAKES AND HELP

The Contractor, unless otherwise instructed, shall stake the Work and shall furnish, without charge, competent personnel from its workforce and such tools, stakes, and other materials as required in properly staking out the Work, in making measurements and surveys and in establishing temporary or permanent reference marks in connection with said Work. The stakes furnished for the staking of the Work shall be of such type, size and quality as to be acceptable to the Public Works Director.

SC-3. PRESERVATION OF MONUMENTS AND STAKES

The Contractor shall carefully preserve all monuments, property corners, bench marks, reference points and stakes, and in case of destruction of the same, will be responsible for proper replacement and for any mistakes or loss of time that may be caused by their unnecessary loss or disturbance. In the event that the loss of stakes, etc., causes a delay in the Work because the Contractor failed to discharge the foregoing obligation, the Contractor shall have no claim for damages or extensions of time. In the case of any permanent monuments, property corners or bench marks which must of necessity be removed or disturbed in the construction of the Work, the Contractor shall carefully protect and preserve the same until they can be properly referenced for relocation. The Contractor shall furnish at its own expense such materials, surveyors and assistance as are necessary for the proper replacement of monuments, property corners or bench marks that have been moved or destroyed.

SC-4. MAINTENANCE OF TRAFFIC

Local traffic on all streets shall be carried through construction whenever possible. Detours of traffic will be permitted when necessary and with the prior written permission of the City. Streets may be closed for short periods of time under authority of proper permit issued by the City or authority having jurisdiction. However, the Contractor shall

conduct its Work so as to interfere as little as possible with public travel, whether vehicular or pedestrian, on such streets. Proper notification to County and City police units and to Fire Districts shall be given by the Contractor before closing any public thoroughfare.

Where construction operations require the closing of private driveways, the Contractor shall give a minimum of 48 hours' notice to the owner or owners thereof and where necessary shall provide temporary access to given property.

SC-5. BORROW AND WASTE AREAS

All borrow materials shall be obtained by the Contractor at its own cost and expense. The borrow area and materials shall be approved by the Public Works Director and shall be friable material suitable for compaction.

All waste areas shall be located off the site and arrangements and payment for use for such areas shall be the sole responsibility of the Contractor. All waste disposal shall be in compliance with federal, state, and local laws, ordinances and regulations.

SC-6. PARKING AREAS, DRIVES AND WALKS

All existing parking areas, drives and walks within the Project limits shall be adjusted to conform to the lines and grades shown on the plans. Any of the above structures that are removed or damaged during construction shall be reconstructed, at Contractor's expense, of materials that will create a quality equal to or better than the condition of the existing facility prior to construction operation.

SC-7. STREET SIGNS AND TRAFFIC AIDS

The Contractor shall be responsible for all preexisting traffic control devices at the Project site, including installation, maintenance, removal and storage of such devices. All temporary and permanent traffic control devices supplied by the Contractor shall comply with and be installed in accordance with the Manual on Uniform Traffic Control Devices, current edition as revised, and the Traffic Control Devices Handbook.

SC-8. EASEMENTS AND RIGHTS-OF-WAY

Permanent and temporary (construction) easements and rights-of-way will be provided by the City as shown on the plans. The Contractor shall confine its operations to the easements provided and shall carefully note where buildings, structures or other obstructions will limit its working space. In the event that easements and rights-of-way are not available or if they have not been secured, or if entry to property is denied by court order, injunction, litigation or any other reason, the Contractor shall cease operations in such area and confine its work to other area approved by the City. In the event of any delay arising from delays in securing easements and rights-of-way, the Contractor may request an extension of time under the General Conditions.

EXHIBIT B-1

PERFORMANCE BOND

KNOW ALL MEN BY THESE PRESENTS, that the undersigned
hereinafter referred to as the "Contractor", and
_____, a Corporation organized under the laws of
the State of _____ and authorized to transact business in
the State of Missouri, as Surety, are held and firmly bound unto the City of Parkville, Missouri,
hereinafter referred to as the "Owner" in the penal sum of
_____ DOLLARS, lawful
money of the United States of America for the payment of which the sum, well and truly to be
made, we bind ourselves and our heirs, executors, administrators, successors, and assigns,
jointly and severally by these presents.

THE CONDITION OF THE FOREGOING OBLIGATION IS SUCH THAT:

WHEREAS, the above bonded Contractor has, on the _____
day of _____, 20____, entered into a written
contract with the aforesaid Owner for furnishing (among other things) all materials, equipment,
tools, superintendence, labor, and other facilities and accessories, for the construction of certain
improvements as designated, defined and described in the said Contract and the Conditions
thereof, and in accordance with the Specifications and Plans therefor, a copy of said Contract
being made a part hereof:

NOW THEREFORE, if the said Contractor shall and will, in all particulars, well, duly and
faithfully observe, perform and abide by each and every covenant, condition, and part of the
Construction work required under said Contract, and the Conditions, Specifications, Plans and
other Contract Documents thereto attached or, by reference, made part thereof, according to
the true intent and meaning in each case, and if said Contractor shall replace all defective parts,
material and workmanship as required by the Contract, then this obligation shall be and become
null and void; otherwise it shall remain in full force and effect.

PROVIDED FURTHER, if said Contractor fails in any particular to duly and faithfully observe,
perform and abide by each and every covenant, condition and part of the said Contract and the
Conditions, Specifications, Plans and other contract documents, thereto attached, or, by
reference made a part thereof, according to the true intent and meaning in each case, or if said
Contractor shall fail to replace all defective parts, material and workmanship as required by the
Contract, then the Surety will promptly advise the City of its election to either complete all of the
obligations of the Contractor; engage another Contractor acceptable to the City to complete the
obligations of the Contractor; or pay the costs incurred by the City to complete the project and/or
the costs to repair any defective parts, and any other damages incurred by the City in procuring

completion and/or repair, such amount not exceeding the amount of this obligation, together with interest as provided by law.

PROVIDED FURTHER, that the said Surety, for value received, hereby stipulates and agrees that no change, extension of time, alteration, or additional to the terms of the contract, or the work to be performed thereunder, or the specifications accompanying the same, shall in any ways affect this obligation on this bond and it does hereby waive notice of any change, extension of time, or addition to the terms of the contract, or to the work, or to the specifications.

IN TESTIMONY WHEREOF, the said Contractor has hereunto set his hand, and the said Surety has caused these presents to be executed in its name, and its corporate seal to be hereunto affixed, by its attorney-in-fact duly authorized hereunto so to do, on this the _____ day of _____, 20_____.

Contractor

ATTEST:

(SEAL) Secretary

By _____

Title

Surety Company

(SEAL) By _____

By _____
Attorney-in-Fact

By _____
Missouri Agent

Surety Claims Address: _____

(Accompany this bond with Attorney-in-Fact's Power of Attorney from the Surety Company certified to include the date of the bond)

EXHIBIT B-2

PAYMENT BOND

KNOW ALL MEN BY THESE PRESENTS, that the undersigned _____ as Contractor, and _____ as Surety with

General Offices in the City of _____ and authorized to transact business in the State of Missouri, are held and firmly bound unto the

CITY OF PARKVILLE, MISSOURI and the STATE OF MISSOURI, in the penal sum of _____ DOLLARS

(\$_____) lawful money of the United States of America, for the payment of which sum well and truly to be made, we bind ourselves, and our heirs, executors, administrators, successors, and assigns, jointly and severally, firmly by these presents:

THE CONDITION OF THE FOREGOING OBLIGATION IS SUCH THAT:

WHEREAS, the said Contractor has on the _____ day of _____, 20_____, entered into a contract with the City of Parkville, Missouri, for furnishing all tools, equipment, materials and supplies, performing all labor, and constructing public improvements described in the Contract, as designated, defined and described in the said Contract and the Conditions thereof, and in accordance with the Specifications and Plans therefor, a copy of said Contract being made a part hereof.

NOW THEREFORE, if the Contractor or the subcontractors of the Contractor shall pay all indebtedness incurred for supplies, materials, or labor furnished, or equipment used or consumed in connection with or in or about the construction or making of the improvements described in the above-mentioned contract documents, this obligation shall be void; otherwise, it shall remain in full force and effect.

The said Surety, for value received, hereby stipulates and agrees that no change, extension of time, alterations or additions to the terms of the Contract or to the work to be performed thereunder, or the specifications accompanying the same, shall in any way affect its obligation on this bond, and it does hereby waive notice of any such change, extension of time, alteration or addition to the terms of the contract or to the work to be performed or to the specifications. The said Surety further agrees that any person to whom there is due any sum for labor or materials furnished, as hereinafter stated or said person's assigns, may bring action on this bond for the recovery of said indebtedness.

IN TESTIMONY WHEREOF, the said Contractor has hereunto set his hand, and the said Surety has caused these presents to be executed in its name, and its corporate seal to be hereunto affixed, by its attorney-in-fact duly authorized thereunto so to do at _____, on this, this _____ day of _____, 20_____

Contractor

ATTEST:

(SEAL) Secretary

By _____

Title

Surety Company

(SEAL)

By _____

By _____
Attorney-in-Fact

By _____
Missouri Agent

Surety Claims Address: _____

(Accompany this bond with Attorney-in-Fact's Power of Attorney from the Surety Company certified to include the date of the bond)

Bond No. _____

MAINTENANCE BOND

KNOW ALL MEN BY THESE PRESENTS, that we, _____ as Principal, and _____ as Surety, are held and firmly bound unto the City of Parkville, Missouri, in the sum of _____ Dollars (\$ _____), for the payment of which sum, well and truly to be made, we hereby bind ourselves, our heirs, executors, administrators, successors and assigns, firmly by these presents.

THE CONDITIONS OF THIS BOND ARE SUCH THAT:

WHEREAS, the said _____ has been given permission by the City Director of Public Works, to construct _____.

NOW THEREFORE, if the said _____ shall construct or cause to be constructed and completed the entire improvement in accordance with specifications used by the city of Parkville for like improvements, and to the lines and grades shown on the plans, all to be done subject to the approval and acceptance of the City Director of Public Works of said city of Parkville, and shall construct said improvement with such materials and in such manner that the same shall endure without need of any repairs for a period of two (2) years from and after the completion of said improvement and acceptance thereof; and if said improvement shall endure without the need of repairs for the period of two (2) years from and after the completion and acceptance thereof as aforesaid, then this obligations shall be void; otherwise to be in full force and effect.

Surety: _____

Principal: _____

By: _____

By: _____

Name _____

Name: _____

Missouri Resident Agent
Attorney-in-Fact, Power of Attorney, Attached

Title _____

Street, City, ZIP

Street, City, ZIP

Phone Number

Phone Number

Approved as to amount of bond:

By _____

Public Works Director

Date _____

Exhibit C

Drawings Attached

NOT FOR CONSTRUCTION

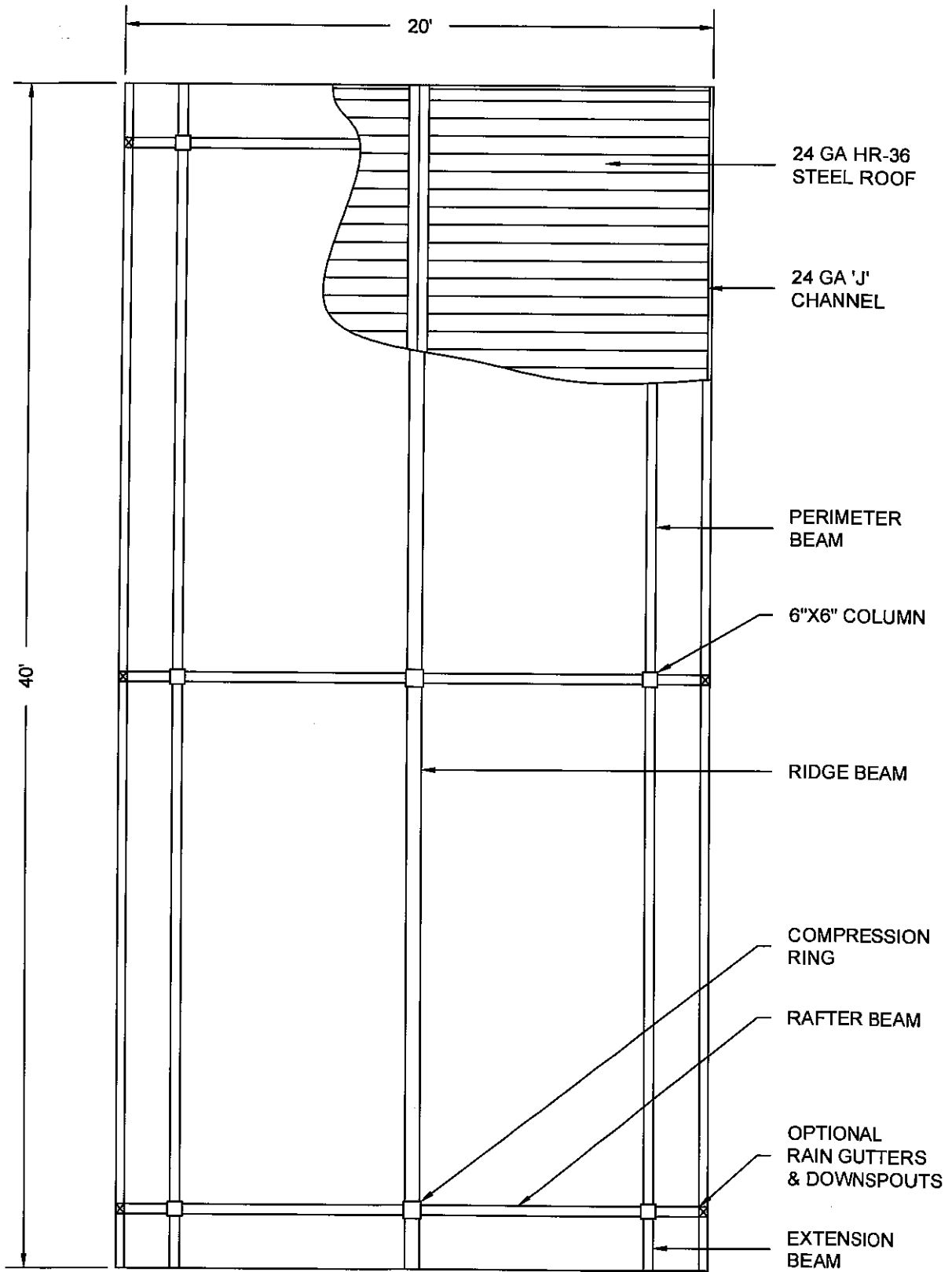

PLAN VIEW 20'X40'

NOT FOR CONSTRUCTION

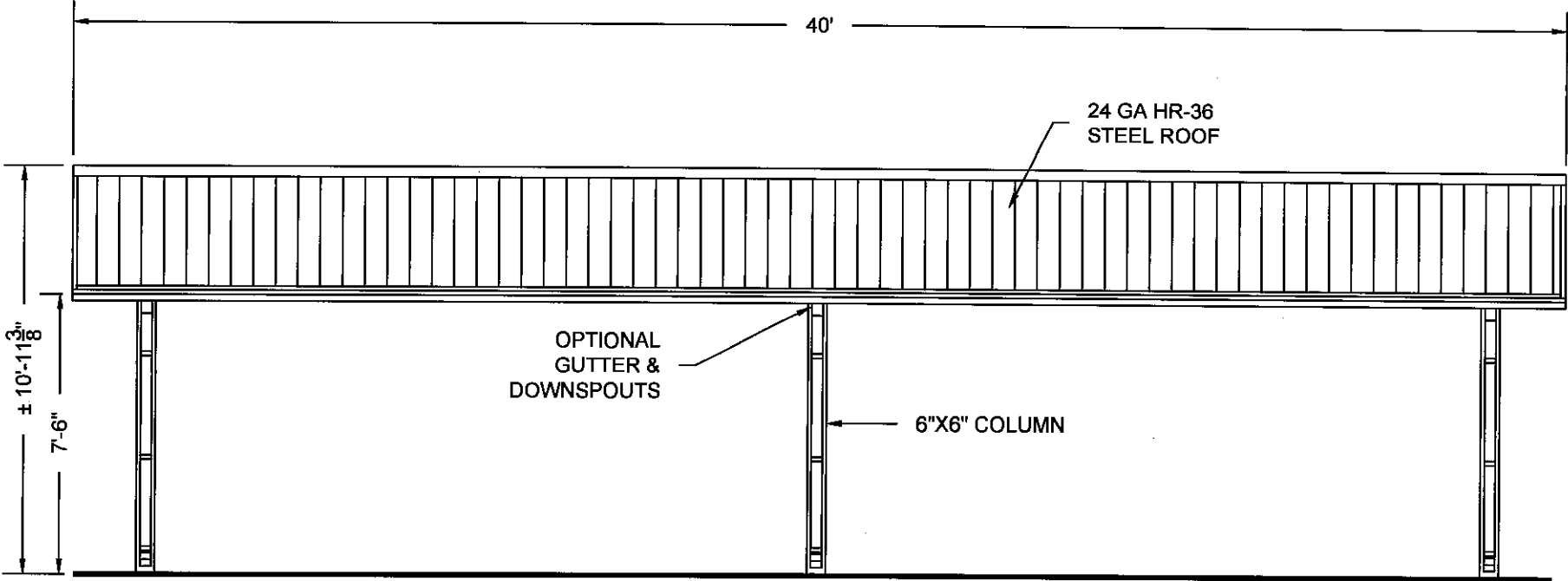

ELEVATION 20'X40'

NOT FOR CONSTRUCTION

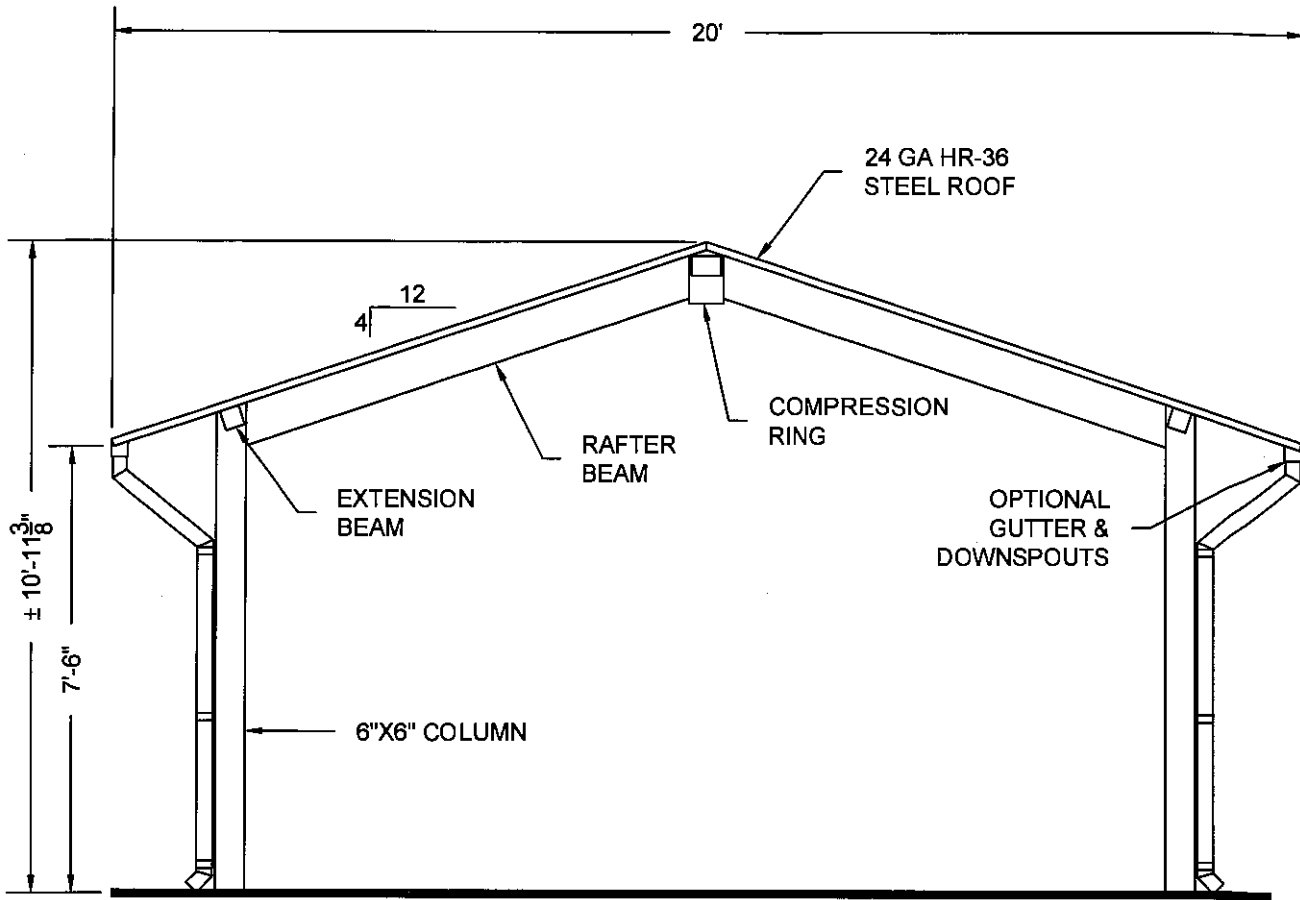

ELEVATION 20'X40'

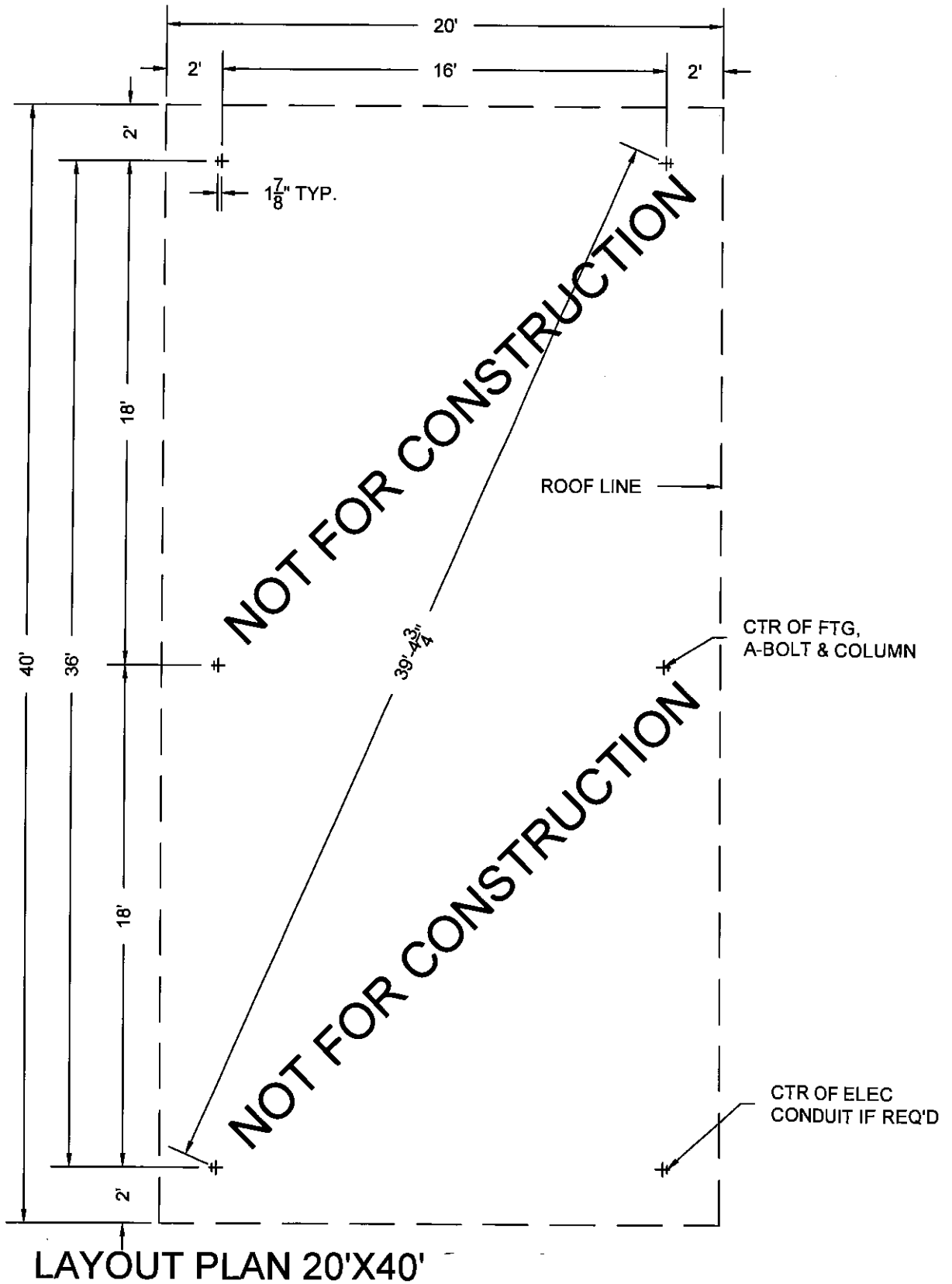

**NOTE: FOR ILLUSTRATION ONLY!
FOOTING SIZE MAY CHANGE w/
STRUCTURAL ENGINEERING**

**ADJUST FTG DEPTH FOR
LOCAL FROST CONDITIONS**

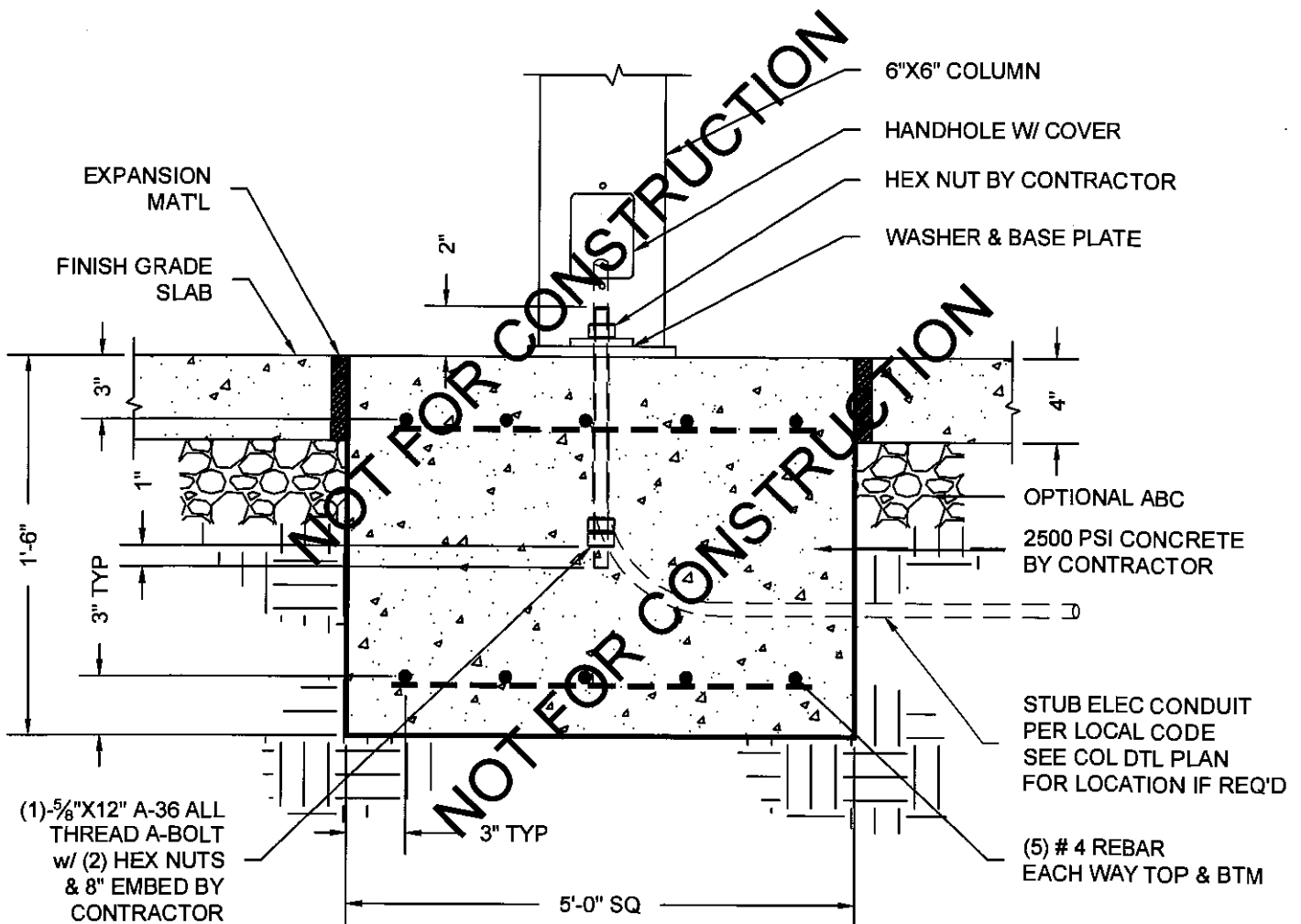
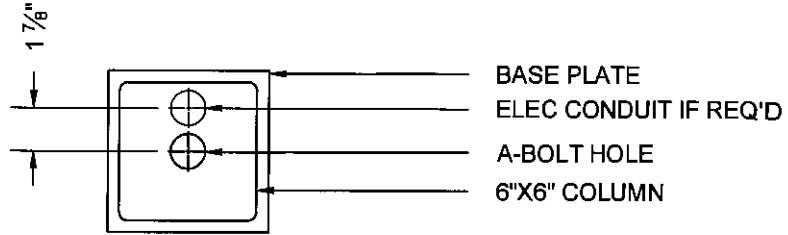

**NON-EXPANSIVE,
UNDISTURBED OR 95%
COMPACTED SUBGRADE**

**1-BOLT SURFACE MOUNT SPREAD FOOTING
20'X40'**

**NOTE: FOR ILLUSTRATION ONLY!
FOOTING SIZE MAY CHANGE w/
STRUCTURAL ENGINEERING**

**ADJUST FTG DEPTH FOR
LOCAL FROST CONDITIONS**

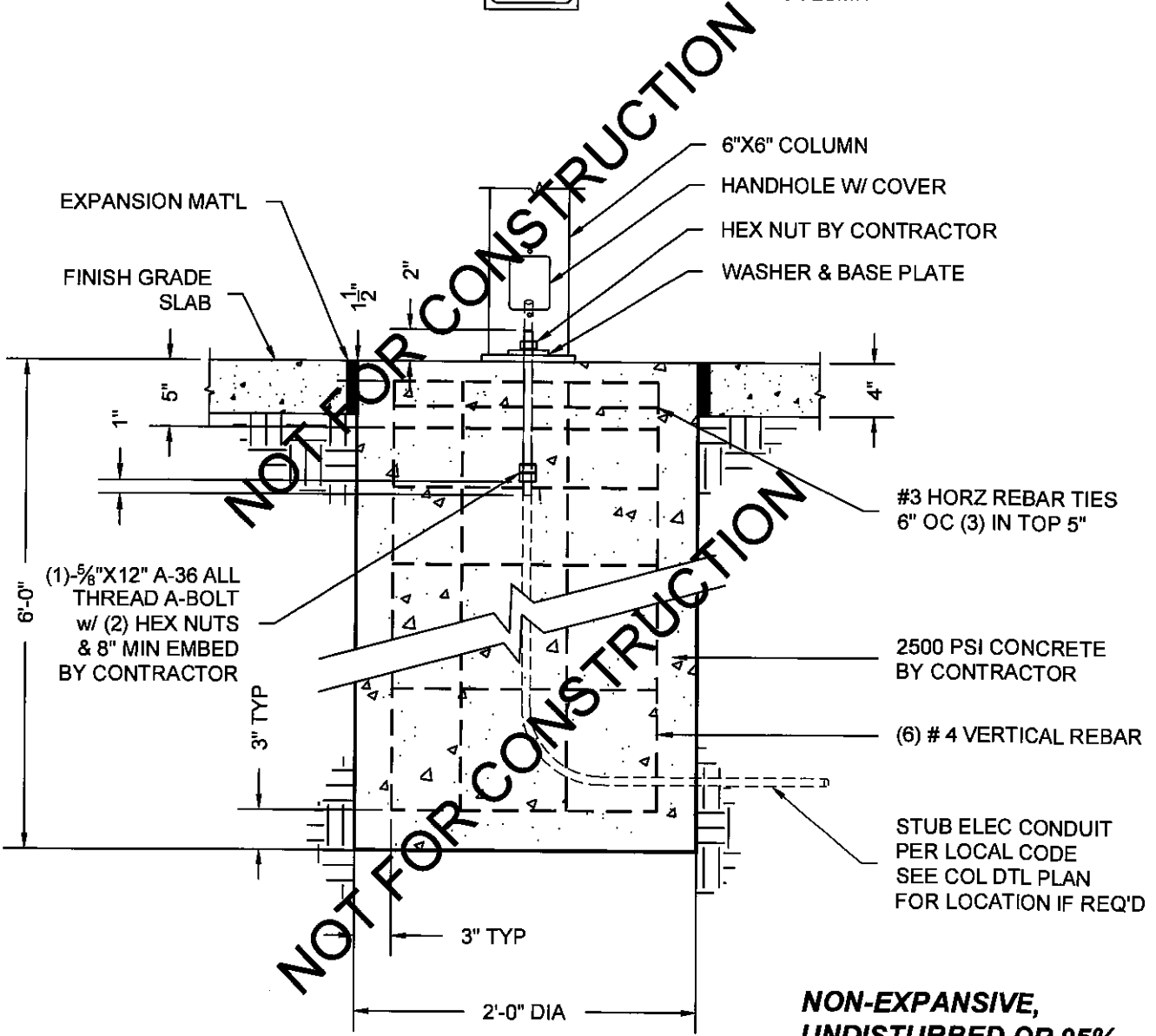
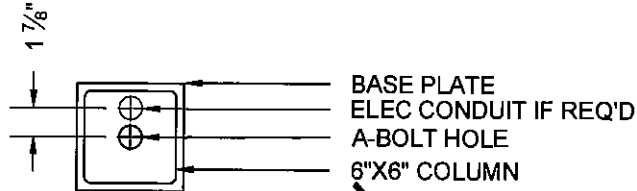

**NON-EXPANSIVE,
UNDISTURBED OR 95%
COMPACTED SUBGRADE**

**1-BOLT SURFACE MOUNT CAISSON FOOTING
20'X40'**

Exhibit D
Specifications Attached

STANDARD SPECIFICATIONS

w/ TRUZINC RICH PRIMER & SUPER DURABLE POWDER COAT PAINT
or approved equivalent

GENERAL:

1. All structures shall be designed and fabricated to the IBC (Latest Edition) or current local building code with standard load designs of the greater value of 20# per S.F. minimum live load and 100 mph sustained wind load or site specific conditions and the applicable zone for seismic loads.
2. All members shall be designed according to the "American Institute of Steel Construction (AISC) specifications and the American Iron and Steel Institute (AISI) specifications for cold-formed members.
3. All fabrication welds shall be in strict accordance with the structural welding code of the American Welding Society (AWS) specifications. All structural welds shall be in compliance with the requirements of "Pre-qualified" welded joints. All welding shall conform to ASTM A-233 series E-70XX electrodes - low hydrogen.
Field welding shall not be required.
4. When required, after award of bid, the shade structure manufacturer shall submit structural calculations, sealed by a registered engineer in the state in which the structure is to be erected for review and approval by the approving agency.
5. Manufacturer qualifications: All manufacturers shall have a minimum of (20) twenty years experience in the fabrication of tubular steel shade structures. Shade structure and kiosk fabrication shall be the manufacturer's primary business. Manufacturer shall have fabricated similar structures to that which is specified. All non-specified manufacturers shall submit complete shop drawings indicating type, size & gauge of material used, with detailed connections to the specifying agency or design firm at least 10 days prior to bid opening for review and written pre-approval. All bids submitted without prior approval will be rejected.

FOOTINGS & COLUMNS:

1. Footings shall be structurally engineered by the structure manufacturer to meet local codes and site conditions. (Sample footing drawings shall be made available to the contractor or owner from the manufacturer). When required for structure installation, anchor bolts shall be supplied by the owner / contractor. Columns shall be ASTM 500 grade B. Concrete footing rebar (if required) shall be ASTM A-615 grade 40 #4 bars & smaller, grade 60 #5 bars & larger. Concrete shall be 5 sack mix "Portland" cement. Maximum slump shall not exceed 4". Concrete compressive strength shall be a minimum of 2500 psi @ 28 days.

FRAME MEMBERS AND COMPRESSION RING:

1. 90% of all steel shall be American (domestic) made. Mill certification shall be made available upon request. All frame members shall be one piece structural steel tube with a minimum .120 (1/8") wall thickness, sized according to engineering. All frame members shall be bolted together with bolts totally concealed. All tubing for frame members shall be ASTM 500 grade B. Beam end plates shall be ASTM A36 fy=36,000 psi UNO. Bolts shall be A 307's, or 325's unless noted otherwise.
"I" beams, Angle iron, "C", "Z" or "S" purlins or beams, open or closed, shall not be allowed.

ROOFING:

1. All roofing shall be 24 gauge Zinalume / Galvalume coated steel panels, ICBO #ER-2757. "HR-36" panels shall be 36" wide with 1½" high ribs @ 7.2". All roofing shall be pre-finished with PVF2 (Polyvinylidene Fluoride) Kynar 500 on the top side. All roof panels shall be pre-cut with ribs running with the slope of the roof. Roof fascia trim shall be 1 ½" "J" channel trim 24 gauge Zinalume / Galvalume coated pre-finished matching the roof color. Screws & rivets shall match roof color. No exceptions taken for roof type or trim.

POWDER COATING:

1. All frame members shall be media blasted to a white finish removing all rust, scale, oil and grease. Powder coating for all frame members shall be provisionally warranted for (5) five years with **TRUZINC** 7520-70138 primer with a Dry Film Thickness of (2.0 - 6.0 mils) & hardness of 2H-3H with a Salt Spray Resistance of **6000 hours** and **Super Durable Gloss Polyester 9000** series finish paint (2.5-3.5 mils) with a hardness of H-H2 & has **1000 hour** salt spray resistance. Total of primer & finish paint shall be 4.5-9.5 mils of paint. Finish shall be a smooth uniform surface with no pits, runs or sags. For additional information, please visit <http://www.tcipowder.com/> for a complete list of specifications.

ERECTION:

1. Manufacturer shall supply complete layout and detail plans with installation instructions for the structure. The structure shall be erected in a work-man-like manner with framing, roofing and trim installed according to the manufacturer's installation instructions. Care shall be taken to avoid damaging the structure during installation. Touch up powder coat paint with paint provided to prevent rusting. Components of the structure shall be covered and kept dry prior to erection.

WARRANTEE:

1. Manufacturer shall warranty the structure to be free from defects in material and workmanship for a period of (10) ten years from date of acceptance by owner. Warranty does not include damage from theft, fire, vandalism or acts of God. Manufacturer shall repair or replace structure components of like kind at his option, to match existing material and workmanship. Steel roof finish shall be warranted for (30) thirty years under a separate roof manufacturer's warranty. Powder coat paint shall be warranted for (5) five years after acceptance from owner against peeling, flaking and rusting. Warranty does not cover damage caused from shipping, erection of structure, lack of touchup and maintenance, overspray from lawn sprinklers or vandalism. Bolt threads are not powder coated and therefore are not covered under the powder coat warranty.

NOTE: Engineering specifications take precedence over drawings if differences occur.

EXHIBIT E

CONTRACTOR'S AFFIDAVIT ACKNOWLEDGING
FEDERAL LOBBYING ACTIVITIES AND
CONFLICT OF INTEREST PROHIBITION

1. 31 U.S.C.S. Section 1352 requires all subgrantees, contractors, subcontractors and consultants who receive federal funds via the City to certify that they will not use federal funds to pay any person for influencing or attempting to influence a federal agency or Congress in connection with the award of any federal contract, grant, loan or cooperative agreements.
2. In addition, contract applicants, recipients and sub recipients must file a form disclosing any expenditures they make for lobbying out of non-federal funds during the contract period.
3. Necessary forms are available from the City Public Works Director and must be returned to the City with other contract documents. It is the responsibility of the Contractor to obtain executed forms from any Subcontractors who fall within the provisions of the Code and to provide the City with the same.

The undersigned has read the foregoing and swears under penalty of perjury that the statements above are true and correct to the best of his information and belief.

(signature)

State of _____)
County of _____)

On this _____ day of _____, 20____, before me, the undersigned, personally appeared _____, _____ of _____, known to me to be the person who executed this document and acknowledged to me that he/she executed the same for the purposes therein stated.

Notary Public in and for said County and State

Commission Expires

Exhibit F

Sales Tax Exemption Documentation

Given upon Award

EXHIBIT G

CONTRACTOR'S AFFIDAVIT OF COMPLIANCE WITH NON-DISCRIMINATION AND EQUAL EMPLOYMENT OPPORTUNITY LAWS

Contractor certifies to The City of Parkville, Missouri, ("The City") that throughout the period covered, Contractor will comply with all applicable provisions of Executive Order 11246 as revised from time to time and as implemented by Title 41 of the Code of Federal Regulations, particularly Chapters 1, 50 and 60, as the same may be amended from time to time.

Contractor further certifies and agrees that each of the following provisions is made a part of the Contract between Contractor and the City:

I. NON-DISCRIMINATION IN EMPLOYMENT

(a) Contractor will recruit and hire employees who are disabled veterans, Vietnam era veterans, and individuals with handicaps and will not discriminate against any employee or applicant for employment because of race, color, religion, sex or national origin. Contractor will take affirmative action to ensure that applicants are employed, and that employees are treated during employment without regard to status such as disabled veterans, Vietnam era veterans, and handicapped individuals or because of race, color, religion, sex or national origin. Such action shall include, but not be limited to, the following employment, upgrading demotion, or transfer, recruitment or recruitment advertising, layoff or termination, rates of pay or other forms of compensation, and selection for training, including apprenticeship. Contractor agrees to post in conspicuous places, available to employees and applicants for employment, notices to be provided by the City setting forth the provisions of this non-discrimination clause.

(b) Contractor will, in all solicitations or advertisements for employees placed by or on behalf of the Subcontractor, state that all qualified applicants will receive consideration for employment without regard to race, color, religion, sex or national origin.

(c) Contractor will send to each labor union or representative of workers with which he has a collective bargaining agreement or other contract of understanding, a notice to be provided by the agency contracting officer, advising the labor union or worker's representative if the Subcontractor's commitments under Equal Opportunity Clause, and shall post copies of the notice in conspicuous places available to employees and applicants for employment.

(d) Contractor will comply with all provisions of Executive Order 11246 of September 24, 1965, and the rules, regulations and relevant orders of the Secretary of Labor.

(e) Contractor will furnish all information and reports required by Executive Order 11246 of September 24, 1965, and by the rules, regulations and orders of the Secretary of Labor, or pursuant thereto, and will permit access to his books, records and accounts by the contracting agency and the Secretary of Labor for purposes of investigation to ascertain compliance with such rules, regulations and orders.

(f) In the event of the Contractor's noncompliance with the Equal Opportunity Clause of this Contract or with any part of such rules, regulations or orders, this subcontract may be canceled, terminated or suspended in whole or in part and the Contractor may be declared ineligible for further Government contracts in accordance with procedures authorized in Executive Order 11246 of September 24, 1965, and such other sanctions may be imposed and remedies invoked as provided in Executive Order 11246 of September 24, 1965, or by rules, regulations or orders of the Secretary of Labor, or as otherwise provided by law.

(g) Contractor will include the provisions of paragraphs (a) through (g) in every subcontract unless exempted by rules, regulations or orders of the Secretary of Labor issued pursuant to Section 204 of Executive Order 11246 of September 24, 1965, so that such provision will be binding upon each subcontractor or vendor. Contractor will take such action with respect to any subcontract as the contracting agency may direct as a means of enforcing such provisions including sanctions for noncompliance. Provided, however, that in the event Contractor becomes involved in, or is threatened with litigation with a subcontractor or vendor as a result of such direction by the contracting agency, Contractor may request the United States to enter into such litigation to protect the interests of the United States.

II. CERTIFICATION OF NONSEGREGATED FACILITIES

Contractor does not, and during the performance of each subcontract with the City, will not maintain or provide for his employees and segregated facilities at any of his establishments, and does not and will not permit his employees to perform their services at any location, under his control, where segregated facilities are maintained. He certifies further that he will not maintain or provide for his employees any segregated facilities at any of his establishments, and that he will not permit his employees to perform their services at any location, under his control, where segregated facilities are maintained. Contractor agrees that a breach of this certification is a violation of the Equal Opportunity Clause in this certificate. As used in this certification, the term "segregated facilities" means any waiting rooms, work areas, restrooms and wash rooms, restaurants and other eating areas, time clocks, locker rooms and other storage or dressing areas, parking lots, drinking fountains, recreation or entertainment areas, transportation and housing facilities provided for employees which are segregated by explicit directive or are in fact segregated on the basis of race, creed, color or national origin, because of habit, local custom or otherwise. Contractor further agrees that (except where he has obtained identical certifications from proposed subcontractors for specific time periods) he will obtain identical certifications from proposed subcontractors prior to the award of subcontracts exceeding \$10,000 which are not exempt from the provisions of the Equal Opportunity Clause; that he will retain such certifications in his files, and that he will forward the following to such proposed subcontractors (except where the proposed subcontractors have submitted identical certifications for specific time periods): NOTICE TO PROSPECTIVE SUBCONTRACTORS OF REQUIREMENT FOR CERTIFICATIONS OF NONSEGREGATED FACILITIES. A Certification of Nonsegregated Facilities, as required by Chapter 60-1.8 of Title 41 of the Code of Federal Regulations must be submitted prior to the award of a subcontract exceeding \$10,000 which is not exempt from the provisions of the Equal Opportunity Clause. The certification may be submitted either for each subcontract or for all subcontracts during a period (i.e., quarterly, semi-annually or annually).

NOTE: Whoever knowingly or willfully makes any false, fictitious or fraudulent representations may be liable for criminal prosecutions under 18 U.S.C. 1001.

III. FILING CERTIFICATE

Contractor has failed or will file the necessary compliance reports, including Standard Form 100 (EEO-1) where and when required by law and applicable regulations, including, without limitation, the Civil Rights Act of 1964 as amended by the Equal Employment Opportunity Act of 1972 and regulations in 41 CFR 60-1.7. Contractor has required and will require similar certification and filing from its non-exempt suppliers.

IV. AFFIRMATIVE ACTION CERTIFICATE

Contractor has developed, is maintaining and will continue to maintain the written affirmative action compliance program to guarantee equal employment opportunity to minority groups required by applicable law and regulations, including, without limitation, those appearing in 41 CFR 60-1.40. Contractor has required and will require similar certification from each of its non-exempt suppliers.

V. UTILIZATION OF SMALL BUSINESS CONCERNS AND DISADVANTAGED SMALL BUSINESS CONCERNS

If the City is required to utilize small business concerns or disadvantaged small business concerns by law or by contract, Contractor agrees to provide any information requested by the City that would be relevant to the issue of whether or not Contractor meets the criteria for these small business concerns. If required by the City, Contractor further agrees to comply with the obligations imposed by 13 CFR §125.9 and FAR §52.219-8, which clauses are incorporated herein by reference.

Executed this _____ day of _____, 20__ by:

Firm/Company Name: _____

Name of Authorized Representative: _____

Signature of Authorized Representative: _____

Title of Authorized Representative: _____

(signature)

State of _____)
County of _____)

On this _____ day of _____, 20____, before me, the undersigned, personally appeared _____, _____ of _____, known to me to be the person who executed this document and acknowledged to me that he/she executed the same for the purposes therein stated.

Notary Public in and for said County and State

Commission Expires

EXHIBIT H

AFFIDAVIT OF COMPLIANCE WITH SAFETY TRAINING REQUIREMENTS

Required by R.S Mo. § 292.675

COUNTY OF)
)
STATE OF) SS.

Before me, the undersigned Notary Public, personally appeared

Who is _____ (title) of
_____ (a corporation/partnership/sole
proprietorship/limited liability company, and states that he/she is authorized to make this
affidavit, and being duly sworn upon his/her oath, deposes and states as follows:

That said company has verified the completion of a 10-hour construction
safety program with respect to the employees working in connection with
the contracted services.

The terms of this affidavit shall have the same meaning as is set forth in
292.675 of the Revised Statutes of Missouri.

Further affiant sayeth naught.

(signature)

Subscribed and sworn to before me this ____ day of _____, 200_

My Commission Expires:

Notary Public

EXHIBIT I

AFFIDAVIT OF COMPLIANCE WITH R.S Mo. §285.530.5

Effective January 1, 2009, all contractors and subcontractors with contract amounts in excess of \$5,000 on public projects in Missouri are required to verify the employment eligibility status of employees through the E-verify federal program administered by the Department of Homeland Security, U.S. Citizenship and Immigration Services. Contractor shall indemnify, defend and hold harmless the City of Parkville Missouri against any expense incurred including imposition of fines which results from violation of such laws. **Contractor affirmatively states that it is not knowingly in violation of R.S. Mo. 285.530.1 and shall not henceforth be in such violation. Contractor further agrees to execute the this sworn affidavit under the penalty of perjury attesting to the fact that the direct Contractor's employees are lawfully present in the United States.** Failure of Contractor to comply with this requirement shall be grounds for termination for default.

COMES NOW Affiant _____, being of lawful age, and states the following based on personal knowledge, under oath and fully aware of the penalties for perjury:

- 1. I presently am employed by _____ ("Contractor") and am authorized by Contractor to make representation on its behalf.
- 2. All of Contractor's employees are lawfully present in the United States.

Further affiant sayeth naught.

Contractor: _____

By: _____

Title: _____

Date: _____

Signature, Print Name

COUNTY OF)
)
STATE OF) SS.

Subscribed and sworn to before me this ____ day of _____, 200_

My Commission Expires:

Notary Public

EXHIBIT J-1
(MISSOURI WAGE ORDER

Missouri

Division of Labor Standards

WAGE AND HOUR SECTION

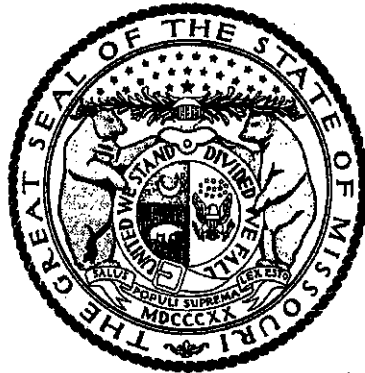

ERIC R. GREITENS, Governor

Annual Wage Order No. 24

Section 083

PLATTE COUNTY

In accordance with Section 290.262 RSMo 2000, within thirty (30) days after a certified copy of this Annual Wage Order has been filed with the Secretary of State as indicated below, any person who may be affected by this Annual Wage Order may object by filing an objection in triplicate with the Labor and Industrial Relations Commission, P.O. Box 599, Jefferson City, MO 65102-0599. Such objections must set forth in writing the specific grounds of objection. Each objection shall certify that a copy has been furnished to the Division of Labor Standards, P.O. Box 449, Jefferson City, MO 65102-0449 pursuant to 8 CSR 20-5.010(1). A certified copy of the Annual Wage Order has been filed with the Secretary of State of Missouri.

Original Signed by

Tammy Cavender
Acting Department Director
Division of Labor Standards

This Is A True And Accurate Copy Which Was Filed With The Secretary of State: March 10, 2017

Last Date Objections May Be Filed: April 10, 2017

Prepared by Missouri Department of Labor and Industrial Relations

OCCUPATIONAL TITLE	** Date of Increase	Basic Hourly Rates	Over-Time Schedule	Holiday Schedule	Total Fringe Benefits
Asbestos Worker (H & F) Insulator		\$36.97	52	53	\$25.45
Boilermaker	6/17	\$36.56	57	7	\$29.13
Bricklayer and Stone Mason	6/17	\$34.74	58	39	\$19.29
Carpenter	6/17	\$37.73	63	68	\$16.85
Cement Mason	6/17	\$31.52	65	4	\$19.06
Communication Technician		\$34.50	47	72	\$21.43
Electrician (Inside Wireman)		\$37.31	13	72	\$17.77 + 10%
Electrician (Outside-Line Construction\Lineman)		\$42.87	125	65	\$5.25 + 34.5%
Lineman Operator		\$39.62	125	65	\$5.25 + 34.5%
Groundman		\$27.63	125	65	\$5.25 + 34.5%
Elevator Constructor		a \$45.49	26	54	\$33.235
Glazier	6/17	\$33.97	88	32	\$18.25
Ironworker	6/17	\$32.65	50	4	\$29.05
Laborer (Building):					
General	6/17	\$27.70	30	4	\$15.90
First Semi-Skilled	6/17	\$28.10	30	4	\$15.90
Second Semi-Skilled	6/17	\$28.50	30	4	\$15.90
Lather		USE CARPENTER RATE			
Linoleum Layer and Cutter	6/17	\$35.39	46	67	\$16.85
Marble Mason	6/17	\$35.16	25	4	\$14.11
Marble Finisher	6/17	\$24.58	25	4	\$8.92
Millwright	6/17	\$37.73	63	68	\$16.85
Operating Engineer					
Group I		\$38.44	85	4	\$16.02
Group II		\$37.63	85	4	\$16.02
Group III		\$32.08	85	4	\$16.02
Group III-A		\$36.29	85	4	\$16.02
Group IV					
Group V		\$33.88	85	4	\$16.02
Painter	6/17	\$29.34	37	4	\$16.86
Pile Driver	6/17	\$37.73	63	68	\$16.85
Pipe Fitter	6/17	\$44.48	2	33	\$21.15
Plasterer	6/17	\$31.79	68	4	\$17.01
Plumber	6/17	\$43.80	45	33	\$21.64
Roofer \ Waterproofer	6/17	\$32.55	95	2	\$18.09
Sheet Metal Worker		\$40.20	17	22	\$21.71
Sprinkler Fitter - Fire Protection		\$36.74	14	4	\$19.62
Terrazzo Worker	6/17	\$35.16	25	4	\$14.11
Terrazzo Finisher	6/17	\$24.58	25	4	\$8.92
Tile Setter	6/17	\$35.16	25	4	\$14.11
Tile Finisher	6/17	\$24.58	25	4	\$8.92
Traffic Control Service Driver		\$15.35	48	49	\$2.71
Truck Driver-Teamster					
Group I		\$30.09	100	4	\$10.90
Group II		\$30.09	100	4	\$10.90
Group III		\$30.29	100	4	\$10.90
Group IV		\$30.29	100	4	\$10.90

Fringe Benefit Percentage is of the Basic Hourly Rate

**Annual Incremental Increase

OCCUPATIONAL TITLE	** Date of Increase	Basic Hourly Rates	Over-Time Schedule	Holiday Schedule	Total Fringe Benefits

* Welders receive rate prescribed for the occupational title performing operation to which welding is incidental.

Use Building Construction Rates on Building construction in accordance with the classifications of construction work established in 8 CSR 30-3.040(2).

Use Heavy Construction Rates on Highway and Heavy construction in accordance with the classifications of construction work established in 8 CSR 30-3.040(3).

a - Vacation: Employees over 5 years - 8%, under 5 years - 6%

**REPLACEMENT PAGE
PLATTE COUNTY
BUILDING CONSTRUCTION - OVERTIME SCHEDULE**

FED: Minimum requirement per Fair Labor Standards Act means time and one-half (1 ½) shall be paid for all work in excess of forty (40) hours per work week.

NO. 2: Means the maximum of eight (8) hours shall constitute a day's work beginning at 8:00 a.m. to 12:00 noon, 12:30 p.m. to 4:30 p.m. The maximum work week shall be forty (40) hours beginning Monday at 8:00 a.m. and ending Friday at 4:30 p.m. Because of traffic, parking or other circumstances, the hours of work on any project may be any continuous 8½ hours period (8 hours of work plus 30 minutes for lunch) between 7:00 a.m. and 4:30 p.m. When circumstances warrant and when it is mutually beneficial and agreed to, the Employer may institute a work week consisting of four (4) consecutive ten (10) hour days, between the hours of 7:00 a.m. and 6:00 p.m. Monday through Thursday, with one-half (½) hour allowed for a lunch period each day. Friday may be used as a make-up day. After ten (10) hours in a workday, or forty (40) hours in a workweek, overtime shall be paid at a rate of one and one-half (1½) times the regular rate of pay. Overtime performed Monday through Saturday shall be paid at the rate of one and one-half (1½) times the regular rate of pay. Sundays and recognized holidays shall be paid at the double (2) time rate of pay. Labor Day shall be paid at triple (3) time. Shift work may be performed at the option of the Contractor. However, whenever shift work is performed it must cover a period not less than (5) consecutive working days. The day shift shall work a regular eight (8) hours shift as outlined above. Employees working a second shift shall receive an additional \$0.25 above the regular hourly rate and perform seven and one-half (7½) hours work for eight (8) hours pay. Third shift employees shall be paid an additional \$0.50 above the regular hourly rate and work seven (7) hours for eight (8) hours pay. In the event a first shift is not required, a second and third shift employee shall receive an additional 15% of the base rate and receive pay for actual hours worked.

NO. 13: Means a regular workday shall consist of eight (8) hours between 8:00 a.m. and 4:30 p.m. Forty (40) hours, within five (5) days -- Monday through Friday inclusive -- shall constitute the regular workweek. The Employer may alter the above stated hours by two (2) hours for an early starting and quitting time only, not to exceed eight (8) hours of work in any one day. When job conditions dictate and as required by the customer, the Employer shall be allowed to establish a four (4) day, ten (10) hour per day work week. This work week is defined as Monday through Thursday, with a Friday make-up day. The normal work day under a ten (10) hour four (4) day work week shall be from 7:00 a.m. to 6:00 p.m., with a one hour starting variance. The make-up day of Friday shall be instituted for specific reasons such as loss of production due to weather and/or holidays. All hours worked in excess of ten (10) hours per day or forty (40) hours per week or hours worked outside the normal work week shall be paid at the applicable overtime rate. The first four (4) hours of overtime after the normal workday, each day Monday through Friday and the first ten (10) hours of overtime on Saturdays shall be paid for at one and one-half (1½) times the regular straight time rate of pay. All other work performed outside of the regularly scheduled working hours and outside of the first ten (10) hours worked on Saturdays shall be paid for at double (2) the regular straight time rate of pay. Sundays and the recognized holidays shall be paid for at double (2) the regular straight time rate of pay, if worked. When so elected by the contractor, multiple shifts of at least five (5) days duration may be worked. When two (2) or three (3) shifts are worked: The first shift (day shift) shall be worked between the hours of 8:00 a.m. and 4:30 p.m. Workmen on the "day shift" shall receive eight (8) hours pay at the regular hourly rate for eight (8) hours work. The second shift (swing shift) shall be worked between the hours of 4:30 p.m. and 12:30 a.m. Workmen on the "swing shift" shall receive eight (8) hours pay at the regular hourly rate plus 10% for seven and one-half (7 ½) hours work. The third shift (graveyard shift) shall be worked between the hours of 12:30 a.m. and 8:00 a.m. Workmen on the "graveyard shift" shall receive eight (8) hours pay at the regular hourly rate plus 15% for seven (7) hours work. A lunch period of thirty (30) minutes shall be allowed on each shift. All overtime work required after the completion of a regular shift shall be paid at one and one-half (1½) times the "shift" hourly rate.

NO. 14: Means eight (8) hours per day shall constitute a day's work. The regular starting time shall be 8:00 a.m., and the regular quitting time shall be 4:30 p.m.; lunch time shall be twelve (12) o'clock noon to 12:30 p.m. The regular starting time may, by mutual consent of employees on the job site, and the employer, be between 7:00 a.m. and 9:00 a.m. with appropriate adjustments made to the regular quitting time and lunch time. All time worked before the regular starting time and after the regular quitting time, Monday through Friday, shall be paid at the rate of time and one-half (1½). Four (4) days at ten (10) hours a day may be worked at straight time. All work commencing with the beginning of the established work day on Saturday shall be paid at the rate of time and one-half (1½). All work commencing with the beginning of the established work day on Sundays and/or Holidays shall be paid at the rate of double (2) time.

**REPLACEMENT PAGE
PLATTE COUNTY
BUILDING CONSTRUCTION - OVERTIME SCHEDULE**

NO. 17: Means the regular working day shall consist of eight (8) hours of labor between 7:00 a.m. and 3:30 p.m. and the regular work week shall consist of five (5) consecutive eight (8) hour days of labor beginning on Monday and ending with Friday of each week. All full-time or part-time labor performed during such hours shall be recognized as regular working hours and paid for at the regular hourly rate. Except as otherwise provided, all work performed outside of regular working hours during the regular work week, shall be at double (2) times the regular rate. Working hours may be varied by two (2) hours. When circumstances warrant and when it is mutually beneficial and agreed to by interested parties, the Employer may institute a work week consisting of four (4) consecutive ten (10) hour days, between the hours of five (5) a.m. and six (6) p.m., Monday through Thursday, with one-half (1/2) hour allowed for a lunch period each day. Friday may be used as a make-up day. The make-up day will be voluntary, and a decision not to work may not be held against the employee. When working four (4) ten (10) hour day's overtime will be paid at the time and one-half (1½) rate for the eleventh (11th) and twelfth (12th) hour, all other work will be paid at the double (2) time rate of pay. The first two (2) hours of overtime, Monday through Friday, and the first eight (8) hours on Saturday shall be at time and one-half (1½) for all work. All other overtime shall be at double (2) time. The first two (2) hours of overtime must be concurrent with the regular work day; two (2) hours prior to or following the regular work day are at time and one-half (1½). The regular workday (as previously defined) on Saturday is paid at time and one-half (1½). Work performed outside of the regular Saturday work day is at double (2) time. All work performed on recognized holidays, or days locally observed as such, and Sundays shall be paid at the double (2) time rate of pay.

NO. 25: Means regular working hours of eight (8) hours shall constitute a working day between the hours of 8:00 a.m. to 4:30 p.m. in a forty (40) hour working week of Monday through Friday. Employment on Saturday, Sunday and legal holidays, and employment before or after the regular working hours shall be considered overtime. Employment on Saturday, Sunday and legal holidays shall be paid for at twice (2) the regular hourly rate. Employment from 4:30 p.m. to 12:00 midnight, Monday through Friday, shall be paid for at one and one-half (1½) times the regular hourly rate. From 12:00 midnight until 8:00 a.m. on any day shall be paid for at twice (2) the regular hourly rate.

NO. 26: Means that the regular working day shall consist of eight (8) hours worked between 6:00 a.m., and 5:00 p.m., five (5) days per week, Monday to Friday, inclusive. Hours of work at each jobsite shall be those established by the general contractor and worked by the majority of trades. (The above working hours may be changed by mutual agreement). Work performed on Construction Work on Saturdays, Sundays and before and after the regular working day on Monday to Friday, inclusive, shall be classified as overtime, and paid for at double (2) the rate of single time. The employer may establish hours worked on a jobsite for a four (4) ten (10) hour day work week at straight time pay for construction work; the regular working day shall consist of ten (10) hours worked consecutively, between 6:00 a.m. and 6:00 p.m., four (4) days per week, Monday to Thursday, inclusive. Any work performed on Friday, Saturday, Sunday and holidays, and before and after the regular working day on Monday to Thursday where a four (4) ten (10) hour day workweek has been established, will be paid at two times (2) the single time rate of pay. The rate of pay for all work performed on holidays shall be at two times (2) the single time rate of pay.

NO. 30: Means Monday through Sunday shall constitute the work week. Regular starting time shall be 8:00 A.M., except when the work week is scheduled as a week with starting time advanced or delayed. Starting time may be advanced or delayed by the employer up to two (2) hours from the regular starting time. Eight (8) hours shall constitute the work day. All work performed prior to or after the regular eight (8) hour work day, as described above, and all work performed on Saturday shall be paid at time and one-half (1½) the regular rate. In the event that a scheduled eight (8) hour work day is missed (not to include holidays) because of events out of the control of the contractor, then that missed work day may be made up at straight time the following Saturday. It is recognized that not all employees working on a Saturday make-up day will have worked the same number of hours during the regular work week. It is further recognized that any work after the forty (40) hours in a week must be paid at time and one-half (1½). Saturday make-up day shall not be used to make up for time lost due to recognized holidays. The employer may establish a 4-10's schedule on projects (4 days with 10 hours per day). If using a 4-10's schedule, a Friday make-up day is allowed. If using a 4 (10) schedule, any work more than ten (10) hours in a day or forty (40) hours in a work week shall be paid at the time and one-half (1½) rate. Friday make-up day shall not be used to make up for time lost due to recognized holidays. All work performed on Sundays or holidays shall be paid at the double (2) time rate.

**REPLACEMENT PAGE
PLATTE COUNTY
BUILDING CONSTRUCTION - OVERTIME SCHEDULE**

NO. 37: The Employer may choose, at his discretion, to work five eight hour days or four ten hour days with a Friday make-up day, Monday through Friday at straight time. Overtime shall be paid after eight (8) hours when working "five eights" and after ten hours when working "four tens". All work performed on Sundays and recognized holidays shall be paid for at the rate of double (2) time. All Saturday work shall be paid for at the rate of time and one-half (1½) the regular wage rate. All night work during the regular work week other than the above-mentioned days shall be paid for at the rate of time and one-half (1½) the regular wage scale until midnight and double (2) time after midnight except make-up time will be allowed under the following condition: In the event of inclement weather on exterior projects which prevents working the full regular eight (8) hour day, forty (40) hour work week schedule, a Saturday make-up day can be granted. Then said work on Saturday shall be paid at the straight time rate of pay up to a maximum total of forty (40) hours per week.

NO. 45: Means eight (8) hours shall constitute a day's work, beginning at 8:00 a.m. and ending at 4:30 p.m. The regular work week shall be forty (40) hours, beginning Monday, 8:00 a.m. and ending at 4:30 p.m. Friday. Because of traffic, parking and other circumstances, the hours of work on any project may begin as early as 6:00 a.m. with eight (8) hours worked between 6:00 a.m. and 4:30 p.m. When circumstances warrant and when it is mutually beneficial and agreed to, the employer may institute a work week consisting of four (4) consecutive ten (10) hour days, between the hours of 7:00 a.m. and 6:00 p.m., Monday through Thursday. Friday may be used as a make-up day. After ten (10) hours in a workday, or forty (40) hours in a workweek, overtime shall be paid at a rate of one and one-half (1½) times the regular rate of pay. All overtime Monday through Saturday shall be paid at the rate of time and one-half (1½) the regular rate of pay. Sunday and recognized holidays shall be paid at double (2) time. Labor Day shall be paid at triple (3) time. Shift work may be performed at the option of the Contractor. However, whenever shift work is performed it must cover a period not less than (5) consecutive working days. The day shift shall work a regular eight (8) hours shift as outlined above. The hourly rate for second shift (seven and one-half hours worked for eight hours paid) shall be twenty-five cents (\$0.25) over and above the hourly rate. The hourly rate for third shift (seven hours worked, eight hours paid) shall be fifty cents (\$0.50) above the hourly rate. If no first shift is worked, second and third shift employees shall receive an additional fifteen percent (15%) over and above the hourly rate for actual hours worked.

NO. 46: Means the regular work day shall be eight (8) hours from 6:00 a.m. to 6:30 p.m. Starting time may be between 6:00 a.m. and 10:00 a.m. The regular work week shall be forty (40) hours, beginning between 6:00 a.m. and 10:00 a.m. on Monday and ending between 2:30 p.m. and 6:30 p.m. on Friday. All hours in excess of the regular work day and work week shall be considered overtime. Overtime on days recognized as regular work days and on Saturday shall be paid for at the rate of time and one-half (1½) the regular rate. Sunday and recognized holidays shall be paid for at the rate of double time (2) for time worked. The Employer may establish a work week consisting of four (4) days, Monday through Thursday, each day consisting of ten (10) hours at straight time rate of pay. The 4-10's must run for a period of at least four (4) days.

NO 47: Means a regular workday shall consist of eight (8) hours between 6:00 a.m. and 6:30 p.m. Forty (40) hours, within five (5) days -- Monday through Friday or Tuesday through Saturday inclusive -- shall constitute the regular workweek. The Employer may alter the above stated hours by two (2) hours for an early starting and quitting time only, not to exceed eight (8) hours of work in any one day. The Employer shall be allowed to establish a four (4) day, ten (10) hour per day work week. This work week is defined as Monday through Thursday, with a Friday make-up day. The normal work day under a ten (10) hour four (4) day work week shall be from 7:00 a.m. to 6:00 p.m. All hours worked in excess of ten (10) hours per day or forty (40) hours per week or hours worked outside the normal work week shall be paid at the applicable overtime rate. The first four (4) hours of overtime after the normal workday, each day Monday through Friday and the first ten (10) hours of overtime on Saturdays shall be paid for at one and one-half (1½) times the regular straight time rate of pay. All other work performed outside of the regularly scheduled working hours and outside of the first ten (10) hours worked on Saturdays shall be paid for at double (2) the regular straight time rate of pay. Sundays and the recognized holidays shall be paid for at double (2) the regular straight time rate of pay, if worked. When so elected by the contractor, multiple shifts of at least five (5) days duration may be worked. When two (2) or three (3) shifts are worked: The first shift (day shift) shall be worked between the hours of 8:00 a.m. and 4:30 p.m. Workmen on the "day shift" shall receive eight (8) hours pay at the regular hourly rate for eight (8) hours work. The second shift (swing shift) shall be worked between the hours of 4:30 p.m. and 12:30 a.m. Workmen on the "swing shift" shall receive eight (8) hours pay at the regular hourly rate plus 10% for seven and one-half (7 ½) hours work. The third shift (graveyard shift) shall be worked between the hours of 12:30 a.m. and 8:00 a.m. Workmen on the "graveyard shift" shall receive eight (8) hours pay at the regular hourly rate plus 15% for seven (7) hours work. A lunch period of thirty (30) minutes shall be allowed on each shift. All overtime work required after the completion of a regular shift shall be paid at one and one-half (1½) times the "shift" hourly rate.

**REPLACEMENT PAGE
PLATTE COUNTY
BUILDING CONSTRUCTION - OVERTIME SCHEDULE**

NO. 48: Means the regularly scheduled work week shall be five (5) consecutive days, Monday through Friday or Tuesday through Saturday. Eight (8) hours shall constitute a day's work. Starting time shall not be earlier than 7:00 a.m. nor later than 10:00 a.m. Forty (40) hours shall constitute a week's work. Overtime at the rate of time and one-half (1½) will be paid for all work in excess of forty (40) hours in any one work week. On the Monday through Friday schedule, all work performed on Saturday will be time and one-half (1½) unless time has been lost during the week, in which case Saturday will be a make up day to the extent of the lost time. On the Tuesday through Saturday schedule, all work performed on Monday will be time and one-half (1½) unless time has been lost during the week, in which case Monday will be a make-up day to the extent of the lost time. Any work performed on Sunday will be double (2) time. If employees work on any of the recognized holidays, they shall be paid time and one-half (1½) their regular rate of pay for all hours worked.

NO. 50: Means eight (8) hours constitute a normal day's work Monday through Friday. Any time worked over eight (8) hours will normally be paid at time and one-half (1½) except for exclusions stated in some following additional sentences. The Employer, at his discretion, may start the work day between 6:00 a.m. and 9:00 a.m. Any schedule chosen shall be started at the beginning of the work week (Monday) and used for at least five days. Work may be scheduled on a four (4) days a week (Monday through Thursday) at ten (10) hours a day schedule. If such a schedule is employed, then Friday may be used as a make-up day when time is lost due to inclement weather. Time and one-half (1½) shall be paid for any work in excess of eight (8) hours in any regular work day Monday through Friday unless working 4-10's, then time and one-half (1½) after ten (10) hours. All work performed on Saturday will be time and one-half (1½). Double (2) time shall be paid for all work on Sundays and recognized holidays.

NO. 52: Means the regular workweek shall consist of five (5) eight (8) hour days, Monday through Friday. The regular workday shall consist of an eight (8) hour period, to be worked between the agreed upon starting time and ending no later than 4:30 p.m. The agreed upon starting time shall be any time between the hours of 6:00 a.m. and 8:00 a.m. The option exists for the employer to use a four (4) day, ten (10) hour work week. Days worked shall be Monday through Thursday or Tuesday through Friday. If the job requires men on duty all five (5) days, then part of the crew may work the first four (4) days and the remainder of the crew may work the last four (4) days. Hours each day shall be from 7:00 a.m. to 5:30 p.m. Interested parties on the project must agree to this clause before it may be used. Once this clause has been put into effect, it shall remain as long as the majority of the Employees on the project and the Employer agree to keep it. The four (4) day clause shall not be used to circumvent a Holiday. Except as otherwise provided, all work performed outside the regular working hours and performed during the regular work week (Monday through Friday) shall be at the following rates of pay:

Holidays-New Year's Day, Memorial Day, Independence Day, Thanksgiving Day, Christmas Day (or days observed as such) shall be recognized as Holidays that shall be paid at two (2) times the regular rate of pay.

Labor Day-No work shall be performed on Labor Day except in special cases of emergency. Rate of pay shall be at three (3) times the regular rate of pay.

Overtime-Work performed outside of the regular work day (the regular work day shall consist of an eight (8) hour period, to be worked between the agreed upon starting time and ending not later than 4:30 p.m. The agreed upon starting time shall be any time between the hours of 6:00 a.m. and 8:00 a.m., by mutual consent of the interested party's.), shall be:

- A. Hours worked Monday through Friday, the first two (2) hours of overtime will be paid at time and one-half (1½). All other overtime will be paid at the double (2) time rate.
- B. The first ten (10) hours worked on Saturday will be paid at time and one-half (1½), with all other hours to be paid at the double (2) time rate.
- C. Sundays and Holidays (except Labor Day) shall be paid at the double (2) time rate.

**REPLACEMENT PAGE
PLATTE COUNTY
BUILDING CONSTRUCTION - OVERTIME SCHEDULE**

NO. 57: Means eight (8) hours per day shall constitute a day's work and forty (40) hours per week, Monday through Friday, shall constitute a week's work. The regular starting time shall be 8:00 a.m. If a second or third shift is used, the regular starting time of the second shift shall be 4:30 p.m. and the regular starting period for the third shift shall be 12:30 a.m. These times may be adjusted by the employer. The day shift shall work a regular eight (8) hours shift as outlined above. Employees working a second shift shall receive an additional \$0.25 above the regular hourly rate and perform seven and one-half (7½) hours work for eight (8) hours pay. Third shift employees shall be paid an additional \$0.50 above the regular hourly rate and work seven (7) hours for eight (8) hours pay. When circumstances warrant, the Employer may change the regular workweek to four (4) ten-hour days at the regular time rate of pay. All time worked before and after the established workday of eight (8) hours, Monday through Friday, and all time worked on Saturday shall be paid at the rate of time and one-half (1½) except in cases where work is part of an employee's regular Friday shift. All time worked on Sunday and recognized holidays shall be paid at the double (2) time rate of pay except in cases where work is part of an employee's previous day's shift. For all overtime hours worked \$27.76 of the fringe benefits portion of the prevailing wage shall be paid at the same overtime rate at which the cash portion of the prevailing wage is to be paid. The remaining \$1.37 of the fringe benefit portion of the prevailing wage may be paid at straight time.

NO. 58: Means eight (8) consecutive hours, between 6:00 a.m. and 5:30 p.m., shall constitute a day's work. Five (5) days work, Monday through Friday, shall constitute a normal work week. Work performed in excess of eight (8) hours per day or eight hours beyond normal starting time for that project excluding lunch Monday through Friday, and all work performed on Saturday, shall be paid for the rate of time and one-half (1½). When Sundays and recognized holidays are worked, the worker(s) shall be paid at the rate of double (2) time. Work may be scheduled on a four (4) days a week (Monday through Thursday) at ten (10) hours a day schedule at straight time. A Friday make-up day is available if time is lost due to inclement weather and at least sixteen (16) hours, but not more than thirty (30) hours, were worked during the week.

NO. 63: Means eight (8) hours shall constitute the regular work day between time that may be advanced or delayed by two (2) hours on either side of 8:00 AM. The Employer may establish a work week consisting of four (4) days, Monday through Thursday, each day consisting of ten (10) hours straight time. The four (4) tens (10s) must run for a period of at least four (4) days, Monday through Thursday. All work on Friday on a four (4) tens (10) project will be paid at the rate of time and one-half (1½). All work performed on Saturday shall be paid at time and one-half (1½). All work performed on Sundays and recognized holidays must be paid at double (2) time. All work performed prior to or after the regular eight (8) hour work day, or ten (10) hour work day, as described above shall be paid at time and one-half (1½) the regular rate.

NO. 65: Means Monday through Sunday shall constitute the work week. Regular starting time shall be 8:00 a.m., with one half hour for lunch between three and one-half (3½) and five (5) hours after starting time. The starting time may be advanced by two (2) hours or delayed one (1) hour by the employer from the regular starting time. All work performed before the advanced starting time and during the half hour lunch shall be paid at the overtime rate of time and one-half (1½). Work performed outside these hours shall be paid at the overtime rate of time and one-half (1½), except as provided otherwise below. All work performed on Sundays or recognized holidays shall be paid at the double (2) time rate. When the start time is delayed past 9:00 a.m., the employee's pay shall start at 9:00 a.m. and all time, after the normal quitting time (5:30 p.m.), shall be paid at the overtime rate. Eight (8) hours shall constitute the work day. All work performed prior to or after the regular eight (8) hour work day, as described above, and all work performed on Saturday shall be paid at time and one-half (1½) the regular rate. In the event that a scheduled eight (8) hour work day is missed (not including recognized holidays) because of inclement weather, then that missed work day may be made up at straight time on the following Saturday. It is recognized that not all employees working on a Saturday make-up day will have worked the same number of hours during the regular work week. It is further recognized that any work after forty (40) hours must be paid at time and one-half (1½). The employer may establish a 4-10's schedule on projects (4 days with 10 hours per day at straight time). In order to use the 4-10's schedule, the employer must schedule the 4-10's for a minimum of one (1) week. If using a 4-10's schedule, a Friday make-up day is allowed.

**REPLACEMENT PAGE
PLATTE COUNTY
BUILDING CONSTRUCTION - OVERTIME SCHEDULE**

NO. 68: Means Monday through Sunday shall constitute the work week. Regular starting time shall be 8:00 a.m., with one half hour for lunch between three and one-half and five hours after starting time. The starting time may be advanced or delayed by the employer up to one hour from the regular starting time. All work performed before the advance starting time and during the half hour lunch shall be paid at the overtime rate of time and one-half (1½). Work performed outside these hours shall be paid at the overtime rate of time and one-half (1½), except as provided otherwise below. All work performed on Sundays or holidays shall be paid at the double (2) time rate. Eight (8) hours shall constitute the work day. All work performed prior to or after the regular eight (8) hour work day, as described above, and all work performed on Saturday shall be paid at time and one-half (1½) the regular rate, except as hereinafter described. In the event that a scheduled eight (8) hour work day is missed (not including recognized holidays) because of inclement weather, then that missed work day may be made up at straight time on the Saturday in the week of the pay period. It is recognized that not all employees working on a Saturday make-up day will have worked the same number of hours during the regular work week. It is further recognized that any work after forty (40) hours must be paid at time and one-half (1½). The employer may establish a 4-10's schedule on projects (4 days with 10 hours per day at straight time). In order to use the 4-10's schedule, the employer must schedule the 4-10's for a minimum of one (1) week. If using a 4-10's schedule, a Friday make-up day is allowed.

NO. 85: Means the work week shall be Monday through Sunday. Eight (8) hours shall constitute a day's work to begin between 6:00 a.m. and 9:00 a.m. and end between 2:30 p.m. to 5:30 p.m. Employees required to work during their lunch period shall receive the overtime rate. Employees shall receive time and one-half (1½) for all time they are required to work prior to their normal starting time or after eight (8) hours or normal quitting time Monday through Friday, or all day on Saturday. If an Employer has started the work week on a five day, eight hours a day schedule, and due to inclement weather misses any time, then he may switch to a nine or ten hours a day schedule, at straight time, for the remainder of that work week in order to make up for the lost time (10-hour make-up day). All work over ten (10) hours a day or over forty (40) hours a week must be paid at time & one-half (1½). Sundays and recognized holidays shall be paid at the double (2) time rate of pay. A contractor may alter the regular work week to four (4) ten (10) hour days at straight time rate of pay. To do this the scheduled 4-10's must be worked at least one full week and the regular workweek shall be Monday through Thursday with Friday being a make-up day at straight time for days missed in the regular workweek due to inclement weather. If 5-8's are being worked, Saturday may be used as a make-up day at straight time if inclement weather prevents work during the normal work week.

NO. 88: Means the regular work week shall consist of five (5) eight (8) hour days, 7:00 a.m. to 3:30 p.m., Monday through Friday, except when the work week is scheduled as a 4-10's week or as a week with start time advanced or delayed as described below. The starting time may be advanced or delayed by one hour on either side of 7:00 a.m. The advanced or delayed starting time must run for a period of at least five (5) days. The Employer may establish a work week consisting of four (4) days, during the regular work week, each day consisting of ten (10) hours at straight time. The 4-10's must run for a period of at least four (4) days. Time and one-half (1½) shall be paid for any work in excess of eight (8) hours in any regular work day Monday through Friday (or ten hours in a 4-10's week), the first eight (8) hours of a Saturday, and it shall be at time and one-half (1½) for the Friday and Saturday following Thanksgiving. Double (2) time shall be paid for the following time worked on Sunday, New Year's Day, Memorial Day, Fourth of July, Labor Day, Thanksgiving Day and Christmas Day, as well as any work in excess of eight (8) hours on a Saturday and the Saturday of a three-day weekend (except the Saturday following Thanksgiving).

NO. 95: Means a regular workday shall consist of eight and one-half (8½) hours elapsed time, including one-half hour for lunch. The crew starting times shall be flexible within the period of daylight to 8:00 a.m. Any work performed over ten (10) hours of elapsed time per day including one-half hour for lunch and/or any work performed over forty (40) hours at the straight time rate in one week shall be paid at time and one-half (1½) the straight time rate. Saturday shall be a voluntary make-up day at straight time at the discretion of the contractor and with the consent of the employees. Sunday and recognized holidays shall be paid for at double (2) time.

**REPLACEMENT PAGE
PLATTE COUNTY
BUILDING CONSTRUCTION - OVERTIME SCHEDULE**

NO. 100: Means eight (8) hours shall constitute a day's work, and five (5) continuous eight-hour days shall constitute a week's work, Monday through Friday. Time and one-half (1½) the regular hourly rate shall be paid for all work performed in excess of eight (8) hours in any one day or forty (40) hours in any one week. Starting time shall be between 6:00 a.m. and 9:00 a.m. All work over eight (8) hours in a regular 5-day 8-hour schedule shall be at the appropriate overtime rate. All time worked before the regular scheduled starting time shall be paid for at the rate of time and one-half (1½) and shall not apply to regular shift. All time worked after eight (8) hours in any one day or after 5:30 p.m., whichever comes first, shall be paid at the time and one-half (1½) rate. An Employer, at his option, may elect to work four (4) ten (10) hour days, Monday through Thursday, at straight time. All such work must be done at least one week in duration. All work over ten (10) hours in one day or forty (40) hours in a week shall be at the overtime rate. Any employee who is scheduled to work on any regular work day but is prevented from working because of weather conditions, shall be permitted to work on Saturday (Friday if working 4-10's) as a make-up day at the straight time rate of pay. When an employee is required to work on any recognized holiday they shall receive the double (2) time rate for all time that they are required to perform work. All time worked from 12:00 Midnight Saturday to 12:00 Midnight Sunday shall be paid for at the rate of double (2) time on single shift.

NO. 125: Eight (8) hours of work between the hours of 8:00 a.m. and 4:30 p.m. shall constitute a work day. Forty (40) hours within the five (5) days, Monday through Friday inclusive, shall constitute the work week. Starting time may be adjusted not to exceed two (2) hours. Work performed outside of the aforementioned will be paid at the applicable overtime rate. When starting time has been adjusted, all other provisions concerning the work day shall be adjusted accordingly. The overtime rate of pay shall be one and one-half (1½) times the regular rate of wages, other than on Sundays, holidays and from Midnight until 6:00 a.m., which will be paid at double (2) the straight time rate.

**PLATTE COUNTY
HOLIDAY SCHEDULE – BUILDING CONSTRUCTION**

NO. 2: All work performed on New Year's Day, Memorial Day, Fourth of July, Labor Day, Thanksgiving Day, Christmas Day, or the days observed as such, shall be paid at the double time rate of pay.

NO. 4: All work done on New Year's Day, Memorial Day, Independence Day, Labor Day, Thanksgiving and Christmas Day shall be paid at the double time rate of pay. If any of the above holidays fall on Sunday, Monday will be observed as the recognized holiday. If any of the above holidays fall on Saturday, Friday will be observed as the recognized holiday and holidays falling on Sunday will be observed on the following Monday.

NO. 7: The following days are assigned days and are recognized as holidays: New Year's Day, Memorial Day, Independence Day, Labor Day, Veteran's Day, Thanksgiving Day, and Christmas Day. If a holiday falls on a Sunday, it shall be observed on the following Monday. If a holiday falls on a Saturday, it shall be observed on the preceding Friday. No work shall be performed on Labor Day except in case of jeopardy to work under construction. This is applied to protect Labor Day. When a holiday falls during the normal workweek, Monday through Friday, it shall be counted as eight (8) hours toward the forty (40) hour week. However, no reimbursement for these eight (8) hours is to be paid to the workman unless worked. If workman are required to work the above enumerated holidays or days observed as such, or on Sunday, they shall receive double (2) the regular rate of pay for such work.

NO. 22: All work performed on New Year's Day, Memorial Day, Independence Day, Labor Day, Thanksgiving Day, Christmas Day, or days locally observed as such, and Sunday shall be recognized as holidays. If a holiday falls on Saturday, Friday shall be observed; if it falls on Sunday, Monday shall be observed. All work performed on holidays shall be paid at the double (2) time rate of pay.

NO. 32: All work performed for the Friday and Saturday following Thanksgiving shall be paid at the time and one-half (1½) rate of pay. All work performed on Sundays, New Year's Day, Memorial Day, Fourth of July, Labor Day, Thanksgiving Day and Christmas Day shall be paid at the double (2) time rate of pay. When one of the above holidays falls on Sunday, the following Monday shall be observed and when one of the above holidays falls on Saturday, the preceding Friday shall be observed.

NO. 33: All work done on New Year's Day, Memorial Day, Fourth of July, Thanksgiving Day and Christmas Day shall be paid at the double time rate of pay. Labor Day shall be paid at the triple (3) time rate of pay. If the holiday falls on Sunday, the following Monday will be observed; if the holiday falls on Saturday, the preceding Friday will be observed.

NO. 39: No work shall be done on the following holidays: New Year's Day, Memorial Day, Independence Day, Labor Day, Thanksgiving Day, and Christmas. Any of these holidays falling on Sunday, the following Monday shall be a holiday, and any of these holidays falling on Saturday, the preceding Friday shall be a holiday.

NO. 49: The following days shall be observed as legal holidays: New Year's Day, Decoration Day, July 4th, Labor Day, Thanksgiving Day, Christmas Day, Employee's birthday and two (2) personal days. The observance of one (1) of the personal days to be limited to the time between December 1 and March 1 of the following year. If any of these holidays fall on Sunday, the following Monday will be observed as the holiday and if any of these holidays fall on Saturday, the preceding Friday will be observed as the holiday. If employees work on any of these holidays they shall be paid time & one-half (1½) their regular rate of pay for all hours worked.

NO. 53: All work done on New Year's Day, Memorial Day, Independence Day, Thanksgiving Day, Christmas Day or days observed as such for these holidays shall be paid at the double (2) time rate of pay. No work shall be performed on Labor Day except in special cases of emergency, and then the rate of pay shall be at three (3) times the regular rate of pay. When a holiday falls on a Sunday, the following Monday shall be observed as the holiday. When a holiday falls on Saturday, the preceding Friday shall be observed as the holiday.

NO. 54: All work performed on New Year's Day, Memorial Day, Independence Day, Labor Day, Veteran's Day, Thanksgiving Day, the Friday after Thanksgiving Day, and Christmas Day shall be paid at the double (2) time rate of pay. When a holiday falls on Saturday, it shall be observed on Friday. When a holiday falls on Sunday, it shall be observed on Monday.

**PLATTE COUNTY
HOLIDAY SCHEDULE – BUILDING CONSTRUCTION**

NO. 65: Work performed on New Year's Day, Memorial Day, Fourth of July, Labor Day, Thanksgiving Day, Christmas Day, or days celebrated as such, shall be paid at the double time rate of pay. If the holiday falls on Saturday, it will be observed on Friday; if the holiday falls on Sunday, it will be observed on Monday, and shall be paid for at double (2) the regular straight time rate of pay.

NO. 67: All work performed on New Year's Day, Memorial Day, Christmas Day, Fourth of July and Thanksgiving Day, from midnight to midnight, shall be paid for at the rate of double time (2) the basic rate of pay if required to work in addition to any other pay otherwise required hereunder as holiday pay. Positively no work shall be performed on Labor Day. Martin Luther King's Birthday, Veteran's Day, and the day after Thanksgiving Day shall be considered optional holidays, and if the Employer and employees agree that work will be performed on that day, no premium pay will be required. Should any of the above holidays fall on Saturday, the holiday will be observed on Friday. Should any of the above holidays fall on Sunday, the holiday will be observed on Monday.

NO. 68: All work performed on New Year's Day, Decoration Day (Memorial Day), Independence Day (Fourth of July), Labor Day, Thanksgiving Day, Christmas Day, or days observed as such, shall be paid at the rate of double (2) time. When a holiday falls on a Saturday, Friday shall be observed. When a holiday falls on a Sunday, Monday shall be observed. No work shall be performed on the Fourth of July or Labor Day except to save life or property. Where one of the holidays specified falls or is observed during the work week, then all work performed over and above thirty-two (32) hours in that week shall be paid at the rate of time and one-half (1½).

NO. 72: All work performed on New Year's Day, Memorial Day (last Monday in May), Independence Day, Labor Day, Thanksgiving Day and Christmas Day shall be paid for at double (2) the regular straight time rate of pay. Any one of the above listed holidays falling on Sunday shall be observed on the following Monday and paid for at double (2) the regular straight time rate of pay, if worked. Any one of the above listed holidays falling on Saturday shall be observed on the prior Friday and paid for at double (2) the regular straight time rate of pay, if worked. No work shall be performed on Labor Day except in case of emergency.

OCCUPATIONAL TITLE	* Date of Increase	Basic Hourly Rates	Over-Time Schedule	Holiday Schedule	Total Fringe Benefits
Carpenter	6/17	\$37.73	1	17	\$16.85
Cement Mason		\$31.50	3	2	\$16.77
Electrician (Outside-Line Construction/Lineman)		\$42.87	18	24	\$5.25 + 34.5%
Lineman Operator		\$39.62	18	24	\$5.25 + 34.5%
Lineman - Tree Trimmer		\$22.51	31	30	\$5.50 + 28%
Groundman		\$27.63	18	24	\$5.25 + 34.5%
Groundman - Tree Trimmer		\$18.21	31	30	\$5.50 + 28%
Laborer					
General Laborer	6/17	\$29.58	3	2	\$15.23
Skilled Laborer	6/17	\$30.79	3	2	\$15.23
Millwright	6/17	\$37.73	1	17	\$16.85
Operating Engineer					
Group I	6/17	\$36.17	3	2	\$16.84
Group II	6/17	\$35.13	3	2	\$16.84
Group III	6/17	\$35.13	3	2	\$16.84
Group IV	6/17	\$30.66	3	2	\$16.84
Oiler-Driver	6/17	\$34.01	3	2	\$16.84
Pile Driver	6/17	\$37.73	1	17	\$16.85
Traffic Control Service Driver		\$15.35	27	26	\$2.71
Truck Driver-Teamster					
Group I	6/17	\$31.49	3	2	\$14.85
Group II	6/17	\$31.49	3	2	\$14.85
Group III	6/17	\$31.49	3	2	\$14.85
Group IV	6/17	\$31.49	3	2	\$14.85

Use Heavy Construction Rates on Highway and Heavy construction in accordance with the classifications of construction work established in 8 CSR 30-3.040(3).

Use Building Construction Rates on Building construction in accordance with the classifications of construction work established in 8 CSR 30-3.040(2).

If a worker is performing work on a heavy construction project within an occupational title that is not listed on the Heavy Construction Rate Sheet, use the rate for that occupational title as shown on the Building Construction Rate sheet.

**PLATTE COUNTY
OVERTIME SCHEDULE - HEAVY CONSTRUCTION**

FED: Minimum requirement per Fair Labor Standards Act means time and one-half (1 ½) shall be paid for all work in excess of forty (40) hours per work week.

NO. 1: Means (8) hours shall constitute the regular work day between time that may be advanced or delayed by two (2) hours on either side of 8:00 AM. The Employer may establish a work week consisting of four (4) days, Monday through Thursday, each day consisting of ten (10) hours straight time. The four (4) tens (10s) must run for a period of at least four (4) days, Monday through Thursday. All work on Friday on a four (4) tens (10) project will be paid at the rate of time and one-half (1½). All work performed on Saturday shall be paid at time and one-half (1½). All work performed on Sundays and recognized holidays must be paid at double (2) time. All work performed prior to or after the regular eight (8) hour work day, or ten (10) hour work day, as described above shall be paid at time and one-half (1½) the regular rate.

NO. 3: Means a regular work week shall consist of not more than forty (40) hours of work and all work performed over and above ten (10) hours per day or forty (40) hours per week shall be paid at the rate of time & one-half (1½). Workers shall receive time and one-half (1½) for all work performed on Sundays and recognized holidays. Double (2) time shall be paid for work performed on Sundays or recognized holidays when and only if any other craft employees of the same employer at work on that same job site are receiving double (2) time pay for that Sunday or Holiday work. A work day is to begin between 6:00 a.m. and 9:00 a.m. at the option of the Employer except when inclement weather or other conditions beyond the reasonable control of the Employer prevents work, in which event, the starting time may be delayed, but not later than 12:00 noon. Where one of the recognized holidays falls or is observed during the work week, then all work performed over and above thirty-two (32) hours in that week shall be paid at the rate of time and one-half (1½).

NO. 18: Eight (8) hours of work between the hours of 8:00 a.m. and 4:30 p.m. shall constitute a work day. Forty (40) hours within the five (5) days, Monday through Friday inclusive, shall constitute the work week. Starting time may be adjusted not to exceed two (2) hours. Work performed outside of the aforementioned will be paid at the applicable overtime rate. When starting time has been adjusted, all other provisions concerning the work day shall be adjusted accordingly. The overtime rate of pay shall be one and one-half (1½) times the regular rate of wages, other than on Sundays, holidays and from Midnight until 6:00 a.m., which will be paid at double (2) the straight time rate.

NO. 27: Means the regularly scheduled work week shall be five (5) consecutive days, Monday through Friday or Tuesday through Saturday. Eight (8) hours shall constitute a day's work. Starting time shall not be earlier than 7:00 a.m. nor later than 10:00 a.m. Forty (40) hours shall constitute a week's work. Overtime at the rate of time and one-half (1½) will be paid for all work in excess of forty (40) hours in any one work week. On the Monday through Friday schedule, all work performed on Saturday will be time and one-half (1½) unless time has been lost during the week, in which case Saturday will be a make up day to the extent of the lost time. On the Tuesday through Saturday schedule, all work performed on Monday will be time and one-half (1½) unless time has been lost during the week, in which case Monday will be a make-up day to the extent of the lost time. Any work performed on Sunday will be double (2) time. If employees work on any of the recognized holidays, they shall be paid time and one-half (1½) their regular rate of pay for all hours worked.

NO. 31: Means the overtime rate shall be time and one-half the regular rate for work over forty (40) hours per week. Sundays and Holidays shall be paid at double the straight time rate. All employees performing work on affected properties during or following emergencies shall receive the applicable rate of pay for the first sixteen (16) consecutive hours and all hours worked in excess of sixteen (16) consecutive hours shall be paid at double time until broken by an eight (8) hour rest period. Should an employee be called back to work within two hours of his normal quitting time, the previous hours worked shall count toward the above sixteen (16) hour provision.

**PLATTE COUNTY
HOLIDAY SCHEDULE – HEAVY CONSTRUCTION**

NO. 2: All work performed on New Year's Day, Decoration Day (Memorial Day), Independence Day (Fourth of July), Labor Day, Thanksgiving Day and Christmas Day, or days observed as such, and Sundays shall be paid at the rate of time and one-half (1½). Double (2) time shall be paid for work on Sundays or recognized holidays when and only if other craft employees of the same employer at work on that same job site are receiving double (2) time pay for that Sunday or holiday work. No work shall be performed on Labor Day, except in case of jeopardy of life or property. This rule is applied to protect Labor Day. When one of the above holidays falls on a Saturday, the preceding Friday shall be observed; when the holiday falls on a Sunday, the following Monday shall be observed. Where one of the specified holidays falls or is observed during the work week, then all work performed over and above thirty-two (32) hours in that week shall be paid at the rate of time and one-half (1½).

NO. 17: All work performed on New Year's Day, Decoration Day (Memorial Day), Independence Day (Fourth of July), Labor Day, Thanksgiving Day, Christmas Day, or days observed as such, shall be paid at the rate of double (2) time. When a holiday falls on a Saturday, Friday shall be observed. When a holiday falls on a Sunday, Monday shall be observed. No work shall be performed on the Fourth of July or Labor Day except to save life or property. Where one of the holidays specified falls or is observed during the work week, then all work performed over and above thirty-two (32) hours in that week shall be paid at the rate of time and one-half (1½).

NO. 24: Work performed on New Year's Day, Memorial Day, Fourth of July, Labor Day, Thanksgiving Day, Christmas Day, or days celebrated as such, shall be paid at the double time rate of pay. If the holiday falls on Saturday, it will be observed on Friday; if the holiday falls on Sunday, it will be observed on Monday, and shall be paid for at double (2) the regular straight time rate of pay.

NO. 26: The following days shall be observed as legal holidays: New Year's Day, Decoration Day, July 4th, Labor Day, Thanksgiving Day, Christmas Day, Employee's birthday and two (2) personal days. The observance of one (1) of the personal days to be limited to the time between December 1 and March 1 of the following year. If any of these holidays fall on Sunday, the following Monday will be observed as the holiday and if any of these holidays fall on Saturday, the preceding Friday will be observed as the holiday. If employees work on any of these holidays they shall be paid time & one-half (1½) their regular rate of pay for all hours worked.

NO. 30: All work performed on New Year's Day, Decoration Day, Fourth of July, Labor Day, Christmas Day, Thanksgiving Day and Day after Thanksgiving or days celebrated for the same.

EXHIBIT J-2

(Prevailing Wage Reporting Form)



MISSOURI DEPARTMENT OF LABOR AND INDUSTRIAL RELATIONS
CONTRACTOR PAYROLL RECORDS
 (See Sections 290.210 to 290.340, RSMo and 8 CSR 30-3.010 to 8 CSR 30-3.060)

Name of <input type="checkbox"/> Contractor <input type="checkbox"/> Subcontractor				Address of Contractor or Subcontractor: City: _____ State: _____ ZIP: _____ Phone Number: () - _____													
Name of Public Body				Address of Public Body: City: _____ State: _____ ZIP: _____ Phone Number: () - _____													
Payroll No.	For Week Ending / /	AWO	Project and Location					Project or Contract No.									
1. Name and Address of Employee	2. Occupational Title ***	3. Day and Date							4. Total Hours	5. Hourly Rate + Cash Fringe	6. Gross Amt Project Week	7. Deductions				8. Net Wages Paid for Week	
		Day	Date									FICA and Medicare	Federal and State Withholding Tax	Other A	Other B		Total Deductions
		Hours Worked Each Day															
		DT															
		OT															
		ST															
		DT															
		OT															
		ST															
		DT															
		OT															
		ST															
		DT															
		OT															
		ST															
		DT															
		OT															
		ST															

*** If a worker performs work in more than one occupational title, you must separately list the hours worked per occupational title and wage rates. ***

43

FRINGE BENEFITS ARE PAID TO APPROVED PLANS, FUNDS, OR PROGRAMS

In addition to the basic rates paid to each laborer or mechanic on the payroll, payments have been or will be made to appropriate programs for the benefit of these employees as shown in the following chart below. If fringe benefit amounts paid are the same for all employees, you may list the amount of each such identical fringe payment only once in the appropriate column; if the fringe benefit amounts vary by employee, list each employee's name and set out the amounts paid on behalf of each employee for each fringe benefit.

Employee Name	Health and Welfare (\$/hr)	Pension (\$/hr)	Vacation (\$/hr)	Holiday (\$/hr)	Apprentice Training (\$/hr)	Other C (\$/hr)	Other D (\$/hr)	Total (\$/hr)	If "Other/Deduction" or Fringes, please explain. (Indicate Other A, B, C or D)	Identify by name, the plan, fund, or programs to which fringe benefits are paid. (Indicate H&W, Pension, etc.)

XX

Date: _____

I, _____ (Name of Signatory Party), _____ (Title) do hereby state:

(1) That I pay or supervise the payment of the persons employed by _____ (Contractor or Subcontractor) on the _____ (Building or Work); that during the payroll period commencing seven (7) days prior to the week ending date of _____ all persons employed on said project have been paid the full weekly wages stated above, that no rebates have been or will be made either directly or indirectly to or on behalf of _____ (Contractor or Subcontractor), from the full weekly wages earned by any person and that no deductions have been made either directly or indirectly from the full wages earned by any person, other than legally permissible deductions, that full and accurate records clearly indicating the names, occupations, and crafts of every worker employed by them in connection with the public work together with an accurate record of the number of hours worked by each worker and the actual wages paid for each class or type of work performed and deduction made for each worker have been prepared, that these payroll records are kept and have been provided for inspection to the authorized representative of the contracting public body and will be available as often as may be necessary and such records shall not be destroyed or removed from the state for the period of one year following the completion of the public work in connection with which the records are made.

(2) That any payrolls otherwise under this contract required to be submitted for the above period are correct and complete; that the wage rates for laborers or mechanics contained therein are not less than the applicable wage rates contained in any wage order incorporated into the contract; that the occupational title set forth herein for each laborer or mechanic conform with the work performed.

(3) That any apprentices employed in the above period are duly registered in a bona fide apprenticeship program registered with a state apprenticeship agency recognized by the Office of Apprenticeship (OA), U.S. Department of Labor (USDOL), or if no such recognized agency exists in a state, are registered with the OA, USDOL.

Name and Title	Signature
The falsification of any of the above statements may subject the contractor or subcontractor to criminal prosecution. See Sections 290.340, 570.090, 575.050, and 575.060, RSMo.	

Missouri Department of Labor and Industrial Relations is an equal opportunity employer/program.

Exhibit J-3

CERTIFICATION OF COMPLIANCE WITH PREVAILING WAGE
REQUIREMENTS

Date: _____

I, _____, _____
(Name of Signatory Party) (Title)

Do hereby state:

(1) That I pay or supervise the payment of the persons employed by _____ that during the payroll period commencing seven (7) days prior to the week ending date of _____ all persons employed on said project have been paid the full weekly wages stated above, that no rebates have been or will be made either directly or indirectly to or on behalf of _____, from the full weekly wages earned by any person and that no deductions have been made by _____ either directly or indirectly from the full wages earned by any person, other than legally permissible deductions, that full and accurate records clearly indicating the names, occupations, and crafts of every worker employed by them in connection with the public work together with an accurate record of the number of hours worked by each worker and the actual wages paid for each class or type of work performed and deduction made for each worker have been prepared, that these payroll records are kept and have been provided for inspection to the authorized representative of the contracting public body and will be available as often as may be necessary and such records shall not be destroyed or removed from the state for the period of one year following the completion of the public work in connection with which the records are made.

(2) That any payrolls otherwise under this contract required to be submitted for the above period are correct and complete; that the wage rates for laborers or mechanics contained herein are not less than the applicable wage rates contained in any wage order incorporated into the contract; that the occupational title set forth herein for each laborer or mechanic conform with the work he/she performed.

(3) That any apprentices employed in the above period are duly registered in a bona fide apprenticeship program registered with a state apprenticeship agency recognized by the Office of Apprenticeship (OA), U.S. Department of Labor (USDOL), or if no such recognized agency exists in a state, are registered with the OA, USDOL.

Signature

The falsification of any of the above statements may subject the contractor or subcontractor to criminal prosecution. See Sections 290.340, 570.090, 575.050, and 575.060, RSMo.

EXHIBIT K

INSURANCE REQUIREMENTS

1. Contractor agrees to procure and carry, at its sole cost, until completion of this Contract and all applicable warranty periods, all insurance as set forth below; provided, however:

1.1 All insurance is to be issued by companies authorized to do business in the state where the project is located, and with liability limits acceptable to City. Insurers shall have A.M. Best ratings of no less than B+ or higher, and at least a Class X financial rating.

1.2 The City reserves the right to review certified copies of any and all insurance policies to which this Contract is applicable.

1.3 Insurance certificates, written on a standard ACORD form, **and a copy of the additional insured endorsement, and endorsement assuring notice of cancellation or modification**, must be received by the City prior to commencement of work on site.

1.4 If Contractor should subcontract any of this work to a third party, Contractor shall see to it that such third party maintains such insurance and shall furnish evidence thereof to the City.

2. Such insurance shall include the following terms and conditions:

2.1 All coverages obtained by Contractor, except professional liability if applicable, shall be on an occurrence policy form and not on a claims made policy form.

2.2 The cost of defense of claims shall not erode the limits of coverage furnished.

2.3 Advance notice of cancellation. All insurance certificates will state that all coverages are in effect and will not be canceled without thirty (30) days' prior written notice ("endeavor to notify" language is not acceptable) to the City and other required additional insureds, and Contractor/Designer shall submit to the City, prior to commencing any Work on the Project, an endorsement to the policy confirming that such notice shall be given. All policies of liability insurance shall contain an endorsement stating the insurers agreement to provide such notice, using CNA form G-140327-B (Ed. 07/11), Travelers Form IL T4 00 (12/09) or other equivalent carrier forms, such as ACORD forms.

2.4 Severability of Interest. All insurance carried shall be endorsed to provide that, inasmuch as this policy is written to cover more than one insured, all terms, conditions, insuring agreements and endorsements, with the exception of limits of liability, shall operate in the same manner as if there were a separate policy covering each insured.

2.5 Comprehensive Automobile Liability Insurance. Contractor shall maintain comprehensive automobile insurance, including contractual liabilities insuring the indemnities set forth in this Contract covering all owned, non-owned and hired automobiles used in connection with the services or other work hereunder, whether on or off the site, and shall have minimum bodily injury and property damage limits of \$1,000,000.00 combined single limit per occurrence. An MCS-90 endorsement shall be procured when applicable.

2.6 Workers' Compensation and Employer's Liability Insurance. Contractor shall maintain Worker's Compensation Insurance to cover the statutory limits of the Workers' Compensation laws of the state in which any work is to be performed and when applicable to Federal Laws, Voluntary Compensation and Employer's Liability (including occupational disease) coverage with limits not less than \$500,000.00 per occurrence and \$1,000,000.00 in aggregate for all workers on site, regardless of whether a worker is also an owner of Contractor.

2.7 Commercial General Liability Insurance. Contractor shall obtain and maintain comprehensive Commercial General Liability Insurance, on an occurrence form for the hazards of (i) construction operations; (ii) subcontractors and sub-subcontractors; (iii) interruption of the City's business; (iv) independent contractors; (v) products and completed operations (with completed operations to remain in force for two years following project completion); (vi) explosion, collapse and underground, and (vii) contractor's protective and contractual liability insuring the indemnities set forth in the Contract, including personal injury, death and property damage. Each Project shall maintain minimum limits of \$2,000,000.00 per occurrence and \$2,000,000.00 aggregate.

2.8 Excess Liability. Contractor shall maintain Excess Liability coverage on an umbrella form with minimum limits of \$2,000,000.00 per occurrence and \$2,000,000.00 aggregate.

2.9 Waiver of Subrogation. All insurance policies supplied shall include a waiver of any right of subrogation of the insurers thereunder against the City and all its assigns, subsidiaries, affiliates, employees, insurers and underwriters. A waiver of subrogation shall be effective as to a person or entity even though that person or entity would otherwise have a duty of indemnification, contractual or otherwise, did not pay the insurance premium directly or indirectly, and whether or not the person or entity has an insurable interest in the property damaged.

2.10 Additional Insureds. The City and any other person or entity required by the Contract, and all their assigns, subsidiaries and affiliates shall be included as additional insureds under Contractor's furnished insurance (except Workers' Compensation Insurance), for ongoing and completed operations, using ISO Additional Insured Endorsement (CG 20 10), edition date 11/85, or an equivalent (e.g., CG 20 10, edition date 10/93, plus CG 20 37, edition date 04/13 or other carrier form) under the commercial general liability policy. Said insurance shall be written on an OCCURRENCE basis, and shall be PRIMARY and NON-CONTRIBUTING.

2.11 Insurance Primary. All policies of insurance provided pursuant to this article shall be written as primary policies, and not in excess of the coverage of the indemnitee's insurance.

3. No Limitation of Liability. The required coverages referred to and set forth herein shall in no way affect, nor are they intended as a limitation on, Contractor's liability with respect to its performance of the Contract.

4. Subcontractors' Insurance. Contractor shall require all those subcontractors providing equipment, materials or services directly to Contractor/ in connection with this Contract to obtain, maintain and keep in force coverages in accordance with the insurance requirements set forth herein during the time they are involved in performance of services or other work

hereunder. Contractor shall obtain certificates of insurance and additional insured endorsements evidencing such coverage and provide the City with such certificates and endorsements. Contractor shall not be excused from its obligations to cause such subcontractor to meet the insurance coverage requirements set forth under this section unless Contractor shall have obtained in writing from the City a waiver, which shall be effective only as to such requirements and for such subcontractor specifically identified therein.

5. Patent Liability. Contractor shall protect, defend and save the City harmless from any liability, including costs and expenses, for, or on account of, any patented or unpatented invention, article or appliance manufactured or used in the performance of this Contract selected by Contractor, and further agrees to pay all loss and expense incurred by the City by reason of any such claims or suits, including attorneys' fees.

6. Professional Liability. If the Contract is entered with a Contractor, and any design or other professional services are included in the Contract, Contractor shall purchase, and maintain for a period of three years after the date of Final Completion, insurance covering claims arising out of the performance or furnishing of Design or Professional Services and for claims arising out of allegations of errors, omissions or negligent acts in connection with the Contract. The policy shall be at least as broad as the coverage provided in Owner' Design Liability Policy, Member Companies of CNA Insurance, Form G-115692-A (Ed 02/96), with a minimum limit of \$1,000,000 per occurrence and \$2,000,000 aggregate.

6.1 With respect to any Professional Liability insurance, Contractor agrees as follows:

- .1 upon receipt of notice of any claim in connection with the Contract, to promptly notify the City, providing full details thereof, including an estimate of the amount of loss or liability.
- .2 promptly notify the City of any reduction of limits or protection afforded under any policy provided, whether or not such impairment came about as a result of events connected to this Contract.
- .3 In the event that the City shall determine that the Contractor/'s aggregate limits of protection shall have been impaired or reduced to such extent that they are deemed inadequate for the balance of the project, Contractor shall upon notice promptly reinstate the original limits of liability required hereunder and shall furnish evidence thereof to the City.

EXHIBIT L

BILL OF SALE

SELLER: _____

In consideration of payments made by _____ (“Buyer”) referenced in the agreement dated _____, 20____, receipt of which is hereby acknowledged, Seller declares and certifies that it now possesses, and does hereby grant, sell, transfer and deliver to Buyer all right, title and interest in the following goods:

Buyer to have all right and title to the goods in himself and his executors, administrators and assigns forever and Seller, on behalf of itself, its successors and assigns, will warrant and defend the title to said goods and chattels hereby sold unto Buyer, its successors and assigns, forever, against the lawful claims and demands of all persons. It is expressly understood and agreed that the acceptance of the goods described herein is not a waiver of any right of action that the Buyer may have for breach of warranty or any other cause under the agreement referenced above or at law.

IN WITNESS WHEREOF, Seller has executed this Agreement the ____ day of _____, 20_____.

Seller: _____

By: _____

Title: _____

Subscribed and sworn to before me this ____ day of _____, 20_____.

Notary Public in and for said County and State

My commission expires:

EXHIBIT M

BAILMENT AGREEMENT

BAILOR:

BAILEE: Contractor/Subcontractor/
Supplier

LOCATION OF STORAGE:

The goods and materials described below are held and stored at the above referenced location pursuant to the Contract by and between Bailee, as Contractor/Subcontractor/Supplier, and City, for Work to be performed at

_____. In consideration of payment made to the undersigned Bailee, the receipt and sufficiency of which are admitted, the Bailee agrees:

1. To keep said goods and materials at the above mentioned address, separate and apart from all other goods and identified as subject to this bailment,
2. To keep said goods and materials fully insured against all risk of physical loss or damage,
3. To keep said goods protected from the weather, commingling, vandalism and/or diversion from said Project, and
4. To deliver said goods and materials to the Project site in conjunction with the performance of Bailee's Contract referenced above or upon the direction of Bailor and no other. The Bailee acknowledges that it has no ownership rights or title in, nor shall claim any lien upon, said goods and materials.

QUANTITY

DESCRIPTION OF ITEM

Received and Acknowledged:

Contractor/Supplier (Bailee)

Dated: _____

By: _____
Authorized Signature

EXHIBIT N

CONDITIONAL PARTIAL RELEASE AND WAIVER OF CLAIMS

To: The City of Parkville, Missouri, the Owner of the real estate (the "Property") identified below, any Lender(s) having any loans secured by the Property, the Applicant's Contractor (if not the General Contractor) and other parties, if any, having any interest in (hereinafter collectively the "Beneficiaries").

The "Property": _____

Description of the "Project": _____

The undersigned hereby applies for payment, certifies and waives lien rights, bond rights and all other claims.

Payment Request Amount: \$ _____

Date of last work covered by payment request: _____

Certificate

The undersigned, contingent upon the issuance, final clearance and payment of a valuable consideration of the sum stated above, and being familiar with the penalties for false certification, does hereby certify to the Beneficiaries that:

1. The amount requested for labor performed and equipment and material supplied on this Project or in connection with the Property reference above, represent the actual value of work accomplished under the terms of the undersigned's agreement and all authorized changes thereto concerning work to be performed on the Property (hereinafter the "Contract").

2. No labor, equipment or materials have been supplied by the undersigned to the Project which have not been included in the applications for payment submitted to date, under any agreement, verbal or written, or any arrangements of any type whatsoever, except as specifically noted here:

3. Payment in full, less retainage and other claims documented as required by the Contract (if any), has been made by the undersigned through the period covered by all prior payments (a) to all of the undersigned's subcontractors, equipment providers, materialmen and laborers, and (b) for all materials and labor used or furnished by the undersigned in connection with the performance of the Contract. The undersigned represents and warrants that it owes no monies or other things of value to any subcontractor, materialman, person or entity for work performed or material supplied through the date of the most recent payment by Owner, except as identified below:

4. The undersigned has complied with Federal, State and Local tax laws, including, without limitation, Income Tax Withholding, Sales Tax, Fringe Benefits owed pursuant to collective bargaining agreements, Social Security, Unemployment Compensation and

Worker's Compensation laws, insofar as applicable to the performance of the contract. Specifically, the undersigned has paid, or out of the proceeds of this payment will promptly pay, all sales or use tax due and owing.

5. The undersigned acknowledges and agrees that it is receiving the funds paid in consideration of this Application as a trustee, and said funds will be held in trust for the benefit of all subcontractors, materialmen, suppliers and laborers who supplied work for which the Beneficiaries or their property might be liable, and that the undersigned shall have no interest in such funds until all these obligations have been satisfied in full.

Partial Waiver and Release of Claims

NOW, THEREFORE, contingent upon the issuance, final clearance and payment of \$_____, the undersigned irrevocably and unconditionally releases and waives any and all claims against the City or any other claims of any kind whatsoever in connection with this Contract and with the Property, also referred to as _____. The undersigned shall indemnify and hold the Beneficiaries and their respective successors and assigns harmless against any claims or suits in connection with the materials, labor, and everything else in connection with this Contract for which payment has been made.

Dated _____, 20__.

CONTRACTOR: _____

By: _____

Name: _____

Title: _____

State of _____)

County of _____)

On this _____ day of _____, 20____, before me, the undersigned, personally appeared _____, _____ of _____, known to me to be the person who executed this document and acknowledged to me that he/she executed the same for the purposes therein stated.

Notary Public in and for said County and State

Commission Expires

EXHIBIT O

CONDITIONAL FINAL WAIVER AND RELEASE OF CLAIMS

To: the City of Parkville, Missouri, the Owner of the real estate (the "Property") identified below, any Lender(s) having any loans secured by the Property, the Applicant's Contractor (if not the General Contractor) and other parties, if any, having any interest in (hereinafter collectively the "Beneficiaries").

The "Property": _____

Description of the "Project": _____

The undersigned hereby applies for payment, certifies and waives lien rights, bond rights and all other claims.

Payment Request Amount: \$ _____

Certificate

The undersigned, contingent upon the issuance, final clearance and payment of a valuable consideration of the amount stated above, and being familiar with the penalties for false certification, does hereby certify to the Beneficiaries that:

1. The amount requested for labor performed and equipment and material supplied on this Project or in connection with the Property reference above, represent the actual value of work accomplished under the terms of the undersigned's agreement and all authorized changes thereto concerning work to be performed on the Property (hereinafter the "Contract").

2. No labor, equipment or materials have been supplied by the undersigned to the Project which have not been included in the applications for payment submitted to date, under any agreement, verbal or written, or any arrangements of any type whatsoever, except as specifically noted here:

3. Payment in full has been made, or with the funds requested hereby will be made, by the undersigned (a) to all of the undersigned's subcontractors, equipment providers, materialmen and laborers, and (b) for all materials and labor used or furnished by the undersigned in connection with the performance of the Contract. The undersigned represents and warrants that it owes no monies or other things of value to any subcontractor, materialman, person or entity for work performed or material supplied through the date of the most recent payment by Owner, and that the payments that have been or will be made out of this final payment to such persons or firms will fully and completely compensate them for all work in connection with the Project.

4. The undersigned has complied with Federal, State and Local tax laws, including, without limitation, Income Tax Withholding, Sales Tax, Fringe Benefits owed pursuant to collective bargaining agreements, Social Security, Unemployment Compensation and Worker's Compensation laws, insofar as applicable to the performance of the contract.

5. The undersigned acknowledges and agrees that it is receiving the funds paid in consideration of this Application as a trustee, and said funds will be held in trust for the benefit of all subcontractors, materialmen, suppliers and laborers who supplied work for which the Beneficiaries or their property might be liable, and that the undersigned shall have no interest in such funds until all these obligations have been satisfied in full.

Final Waiver and Release of Claims

NOW, THEREFORE, the undersigned, contingent upon the issuance, final clearance and payment of \$_____, which the undersigned irrevocably and unconditionally releases and waives any and all mechanic's liens or other liens or right to claim any and all claims against the Owner, its sureties or on any bonds, or any other claims of any kind whatsoever in connection with this Contract and with the Property. The undersigned shall indemnify and hold the Beneficiaries and their respective successors and assigns harmless against any claims or suits in connection with the materials, labor, and everything else in connection with this Contract.

Dated _____, 20__.

CONTRACTOR: _____

By: _____
Name: _____
Title: _____

State of _____)
County of _____)

On this _____ day of _____, 20____, before me, the undersigned, personally appeared _____, _____ of _____, known to me to be the person who executed this document and acknowledged to me that he/she executed the same for the purposes therein stated.

Notary Public in and for said County and State

Commission Expires

Certificate of Substantial Completion

PROJECT:

(Name and address)

CONTRACT FOR: _____

CONTRACT DATE: _____

TO OWNER:

CITY OF PARKVILLE, MISSOURI
Attention: Director of Public Works
City Hall
8880 Clark Avenue
Parkville, MO 64152

TO CONTRACTOR:

(Name and address)

**PROJECT OR PORTION OF THE PROJECT DESIGNATED FOR PARTIAL
OCCUPANCY OR USE SHALL INCLUDE:**

The Work performed under this Contract has been reviewed and found, to the Professional's best knowledge, information and belief, to be substantially complete. Substantial Completion is the stage in the progress of the Work when the Work or designated portion is sufficiently complete in accordance with the Contract Documents so that the Owner can occupy or utilize the Work for its intended use. The date of Substantial Completion of the Project or portion designated above is the date of issuance established by this Certificate, which is also the date of commencement of applicable manufacturer's warranties required by the Contract Documents, except as stated below:

Date of Commencement: _____

**DESIGN PROFESSIONAL
ISSUANCE**

BY

DATE

OF

Punch List of items to be completed or corrected is attached hereto. The failure to include any items on such list does not alter the responsibility of the Contractor to complete all Work in accordance with the Contract Documents. Unless otherwise agreed to in writing, the date of commencement of manufacturer's warranties for items on the attached list will be the date of issuance of the final Certificate of Payment or the date of final payment.

Cost estimate of Work that is incomplete or defective: \$ _____

The Contractor will complete or correct the Work on the list of items attached hereto within ___ days from the above date of Substantial Completion.

CONTRACTOR

BY

DATE

The Owner accepts the Work or designated portion as substantially complete and will assume full possession at ____ (time) on _____ (date).

OWNER

BY

DATE

The responsibilities of the Owner and Contractor for security, maintenance, heat, utilities, damage to the Work and insurance shall be as stated on the attached list.

Certificate of Final Completion

PROJECT:

(Name and address)

CONTRACT FOR:_____

CONTRACT DATE:_____

TO OWNER:

CITY OF PARKVILLE, MISSOURI
Attention: Director of Public Works
City Hall
8880 Clark Avenue
Parkville, MO 64152

TO CONTRACTOR:

(Name and address)

The Work performed under this Contract has been reviewed and found, to the Professional's best knowledge, information and belief, to be finally complete. The date of Final Completion of the Project is the date of issuance established by this Certificate.

DESIGN PROFESSIONAL

BY

DATE OF ISSUANCE

Construction Change Directive

PROJECT (*Name and address*):

DIRECTIVE NUMBER:

DATE:

CONTRACT FOR:

TO CONTRACTOR (*Name and Address*):

CONTRACT DATED:

You are hereby directed to make the following change(s) in this Contract:

PROPOSED ADJUSTMENTS

1. The proposed basis of adjustment to the Contract Sum or Guaranteed Maximum Price is:
 - Lump Sum decrease of \$0.00
 - Unit Price of \$_____ per
 - As follows:

2. The Contract Time is proposed to (remain unchanged). The proposed adjustment, if any, is ____ days.

When signed by the Owner and received by the Contractor, this document becomes effective IMMEDIATELY as a Construction Change Directive (CCD), and the Contractor shall proceed with the change(s) described above.

Contractor signature indicates agreement with the proposed adjustments in Contract Sum and Contract Time set forth in this CCD.

OWNER (*Firm name*)

CONTRACTOR (*Firm Name*)

ADDRESS

ADDRESS

BY (*Signature*)

BY (*Signature*)

(*Typed name*)

(*Typed name*)

DATE

DATE

Change Order

PROJECT (*Name and address*):

CHANGE ORDER NUMBER:
DATE:

TO CONTRACTOR (*Name and Address*):

PROJECT NO.: _____
CONTRACT DATE:

THE CONTRACTOR IS CHANGED AS FOLLOWS:

The original Contract Sum was	\$	_____
The net change by previously authorized Change Orders	\$	_____
The Contract Sum prior to this Change Order was	\$	_____
The Contract Sum will be increased/decreased by this Change Order in the amount of	\$	_____
The new Contract Sum including this Change Order will be	\$	_____

The Contract Time will be increased by _____ () days.
The date of Substantial Completion as of the date of this Change Order therefore is

This Change Order represents a complete and final resolution of all matters concerning or arising out of the work described in the Change Order, including any impact, delay, disruption and/or acceleration of work unless specifically identified herein.

NOT VALID UNTIL SIGNED BY THE CONTRACTOR AND OWNER.

CONTRACTOR (*Firm name*)

OWNER (*Firm Name*)

ADDRESS

ADDRESS

BY (*Signature*)

BY (*Signature*)

(*Typed name*)

(*Typed name*)

DATE

DATE